

Wrench Series 扳手工具

AE70°扳手

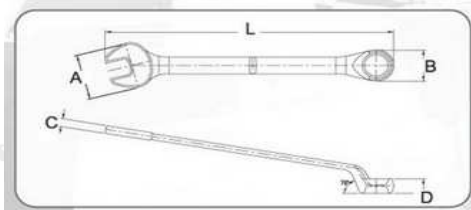
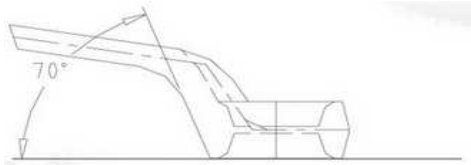

CONFORMS TO DIN 3113 STANDARD

SIZE	L	A	B	C	D	G
6	102	15.2	10.3	3.9	5.1	16
7	112	17.3	11.5	4.1	6.3	20
8	122	19.2	13.1	4.3	6.6	25
9	131	21.1	14.0	4.8	7.3	33
10	140	23.1	15.7	4.8	8.2	41
11	150	25.0	17.0	5.3	8.4	50
12	160	26.4	18.7	5.4	9.0	58
13	170	29.2	21.1	5.5	9.5	74
14	180	31.4	21.6	5.8	9.7	88
15	190	33.1	22.9	6.2	9.7	103
16	200	34.8	24.3	6.0	10.5	116
17	210	36.3	25.2	6.5	11.5	135
18	220	38.7	27.3	6.7	13.0	155
19	230	40.4	28.3	7.2	13.4	184
21	260	46.6	30.8	7.8	14.8	247
22	260	46.6	30.8	7.8	14.8	247
24	280	50.4	34.4	8.3	15.2	311
27	310	55.3	38.4	8.5	16.2	390
30	340	61.0	41.7	9.2	18.2	500
32	360	65.5	44.5	10.1	19.5	621

AR 2代平面扳手

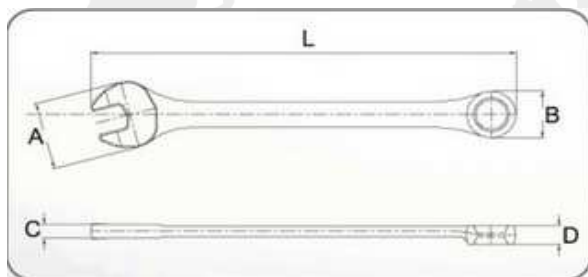

CONFORMS TO AMERICAN NATIONAL STANDARD INSTITUTE (ANSI)

SIZE	L	A	B	C	D	G
6	98	14.3	9.6	3.9	4.6	16
7	98	14.3	9.6	3.9	4.6	16
8	102	17.9	11.4	4.2	4.9	20
9	116	21.9	14.8	5.0	6.4	36
10	123	23.1	16.8	5.5	7.0	39
11	131	24.0	17.4	5.5	7.7	44
12	138	25.5	19.0	5.7	8.1	53
13	148	27.0	20.2	5.9	8.7	62
14	168	30.6	21.7	6.2	8.9	83
15	189	32.3	23.9	6.6	9.7	107
16	189	32.6	23.9	6.6	9.7	107
17	207	36.6	26.6	7.0	10.1	135
18	230	38.8	28.4	7.7	10.6	165
19	230	38.8	28.4	7.7	10.6	165
20	260	42.7	31.2	9.4	11.7	219
21	260	42.7	31.2	9.4	11.7	219
22	284	44.3	33.4	8.8	12.3	256
23	284	44.3	33.4	8.8	12.3	256
24	310	49.1	36.1	9.5	12.5	350
25	333	51.0	37.7	10.7	13.4	395
26	333	51.0	37.7	10.7	13.4	395
27	361	53.9	38.9	12.6	15.9	422
28	361	53.9	38.9	12.6	15.9	422
29	382	57.3	43.2	13.1	16.3	624
30	382	57.3	43.2	13.1	16.3	624
32	412	62.6	44.7	13.9	17.7	698
1/4	98	14.3	9.6	3.9	4.6	16
5/16	102	17.9	11.4	4.2	4.9	20
11/32	116	21.9	14.8	5.0	6.4	36
3/8	116	21.9	14.8	5.0	6.4	36
7/16	131	24.0	17.4	5.5	7.7	44
1/2	148	27.0	20.2	5.9	8.7	62
9/16	168	30.6	21.7	6.2	8.9	83
5/8	189	32.6	23.9	6.6	9.7	107
11/16	207	36.6	26.6	7.0	10.1	135
3/4	230	38.8	28.4	7.7	10.6	165
13/16	260	42.7	31.2	9.4	11.7	219
7/8	284	44.3	33.4	8.8	12.3	256
15/16	310	49.1	36.1	9.5	12.5	350
1"	333	51.0	37.7	10.7	13.4	395
1-1/16	361	53.9	38.9	12.6	15.9	422
1-1/8	382	57.3	43.2	13.1	16.3	624
1-1/4	412	62.6	44.7	13.9	17.7	698

Wrench Series 扳手工具

CWAD45° 扳手

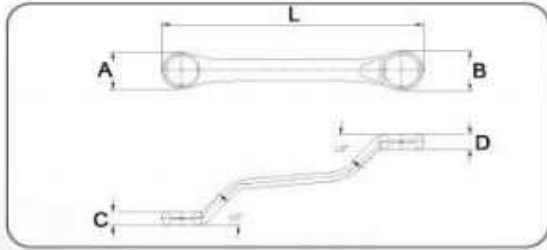

CAR REPAIR

SIZE	L	A	B	C	D	G
10 x 11	115	15.3	17.8	6.9	7.0	48
10 x 12	115	15.3	17.8	6.9	7.0	48
10 x 13	115	15.9	20.5	7.7	8.0	55
12 x 13	140	20.0	22.0	8.9	9.1	70
12 x 14	140	20.0	22.0	8.9	9.1	70
14 x 15	148	24.5	25.9	10.0	10.4	100
14 x 17	148	24.5	25.9	10.0	10.4	100
16 x 18	148	24.5	25.9	10.0	10.4	100
17 x 19	155	25.0	28.6	10.8	11.3	123
3/8 x 7/16	122	15.3	17.8	6.9	7.0	48
1/2 x 9/16	147	20.0	22.0	8.9	9.1	70
5/8 x 11/16	162	24.5	25.9	10.0	10.4	100
5/8 x 3/4	175	25.0	28.6	10.8	11.3	123

CWAS 扳手

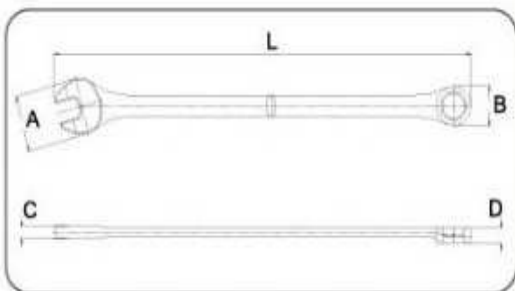

CAR REPAIR

SIZE	L	A	B	C	D	G
6	128	13.1	9.5	3.7	4.9	24
7	138	13.1	9.5	3.7	4.9	24
8	148	16.5	11.0	4.6	5.2	30
9	160	18.0	12.3	4.9	6.0	35
10	167	21.6	14.6	5.1	6.4	45
11	186	23.7	16.2	5.8	6.8	60
12	196	25.7	18.5	6.2	7.6	71
13	205	27.2	20.2	6.8	8.9	95
14	223	30.3	21.5	7.4	9.3	119
15	233	33.5	23.8	8.5	10.7	155
16	233	33.5	23.8	8.5	10.7	155
17	262	34.7	25.6	8.7	11.7	195
18	271	38.4	28.1	8.6	12.0	237
19	281	38.8	27.4	8.7	12.4	215
20	301	43.2	30.8	9.5	13.2	295
21	301	43.2	30.8	9.5	13.2	295
22	319	45.5	32.3	9.6	13.9	300
23	339	47.8	33.8	9.8	14.7	375
24	339	47.8	33.8	9.8	14.7	375
25	358	52.2	37.0	11.2	15.9	491
26	358	52.2	37.0	11.2	15.9	491
27	388	56.1	39.4	11.7	18.4	625
28	388	56.1	39.4	11.7	18.4	625
29	404	60.4	42.2	12.5	18.5	721
30	404	60.4	42.2	12.5	18.5	721
32	430	64.6	45.7	13.5	20.1	840
1/4	128	13.1	9.5	3.7	4.9	24
5/16	148	16.5	11.0	4.6	5.2	30
3/8	167	21.6	14.6	5.1	6.4	45
7/16	186	23.7	16.2	5.8	6.8	60
1/2	205	27.2	20.2	6.8	8.9	95
9/16	223	30.3	21.5	7.4	9.3	119
5/8	233	33.5	23.8	8.5	10.7	155
11/16	262	34.7	25.6	8.7	11.7	195
3/4	281	38.8	27.4	8.7	12.4	215
13/16	301	43.2	30.8	9.5	13.2	295
7/8	319	45.5	32.3	9.6	13.9	300
15/16	339	47.8	33.8	9.8	14.7	375
1"	358	52.2	37.0	11.2	15.9	491
1-1/16	388	56.1	39.4	11.7	18.4	625
1-1/8	404	60.4	42.2	12.5	18.5	721
1-1/4	430	64.6	45.7	13.5	20.1	840

Wrench Series 扳手工具

CWE 扳手

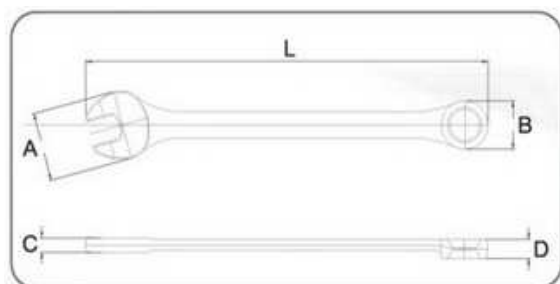

CONFORMS TO DIN 3113 STANDARD

SIZE	L	A	B	C	D	G
6	102	15.7	10.4	3.6	4.5	17
7	112	17.2	11.6	4.0	4.9	20
8	122	19.6	12.8	4.5	5.3	26
9	132	21.5	14.6	4.7	5.7	35
10	140	23.8	16.2	4.9	6.6	40
11	150	25.6	17.5	5.0	6.9	50
12	160	27.4	18.4	5.4	7.2	59
13	170	29.6	19.8	5.9	7.7	75
14	180	31.7	21.6	6.2	8.6	92
15	190	33.2	23.1	6.5	8.7	95
16	200	34.7	24.5	6.6	8.9	109
17	210	36.8	25.8	6.7	8.9	122
18	220	38.8	26.9	7.1	9.9	149
19	230	40.8	28.6	7.4	10.3	165
20	240	43.0	29.7	7.6	10.5	185
21	250	45.3	31.8	7.8	11.0	209
22	260	46.6	32.7	8.0	11.7	231
23	270	47.7	33.5	8.4	11.9	234
24	280	50.4	35.9	8.5	12.2	274
25	290	52.5	36.9	8.8	12.3	286
26	300	53.0	38.2	9.0	12.4	310
27	310	53.3	38.5	9.2	12.5	330
28	320	56.6	40.5	9.3	12.6	388
29	330	59.0	41.4	9.5	12.8	419
30	340	62.3	43.9	9.9	13.2	474
32	360	65.7	45.7	10.3	14.0	523
33	380	69.2	50.2	11.6	15.7	686
34	380	69.2	50.2	11.6	15.7	686
35	410	74.6	54.3	13.2	18.5	878
36	410	74.6	54.3	13.2	18.5	878
38	440	77.0	57.0	14.4	19.0	968
41	460	83.6	61.3	14.5	21.5	1234
42	460	83.6	61.3	14.5	21.5	1234
43	460	83.6	61.3	14.5	21.5	1234
44	500	89.3	63.9	15.0	21.7	1566
45	500	89.3	63.9	15.0	21.7	1566
46	500	89.3	63.9	15.0	21.7	1566
48	540	97.0	73.5	16.9	23.1	1951
50	540	97.0	73.5	16.9	23.1	1951

CWAD 扳手

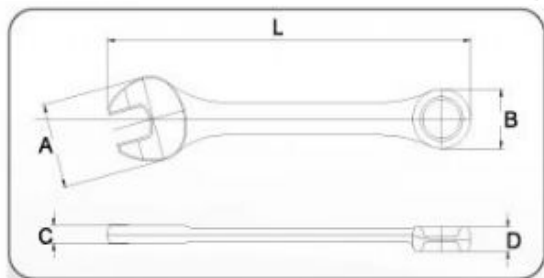

CAR REPAIR

SIZE	L	A	B	C	D	G
6	77	13.1	10.0	4.6	5.8	14
7	80	15.8	10.3	5.0	5.8	17
8	85	17.8	13.5	5.2	5.9	22
9	90	18.9	14.2	5.2	6.0	29
10	95	22.2	16.1	5.8	7.5	37
11	100	23.9	17.9	6.1	7.8	45
12	104	25.5	19.1	6.6	7.8	51
13	109	27.1	19.9	7.0	9.1	54
14	114	29.2	21.8	7.6	9.4	71
15	120	30.1	22.5	7.8	9.6	76
16	124	32.8	24.1	7.9	9.8	88
17	130	35.8	26.1	8.7	10.8	115
18	134	36.7	27.0	9.1	11.0	118
19	140	38.1	28.6	9.9	11.9	148
22	165	39.7	29.8	10.3	12.5	220
1/4	77	13.1	10.0	4.6	5.8	14
5/16	85	17.8	13.5	5.2	5.9	22
3/8	95	22.2	16.1	5.8	7.5	37
7/16	100	23.9	17.9	6.1	7.8	45
1/2	109	27.1	19.9	7.0	9.1	54
9/16	114	29.2	21.8	7.6	9.4	71
5/8	124	32.8	24.1	7.9	9.8	88
11/16	130	35.8	26.1	8.7	10.8	115
3/4	140	38.1	28.6	9.9	11.9	148

Wrench Series 扳手工具

TRQ快速扳手

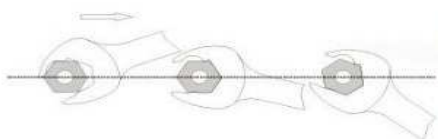

CONFORMS TO AMERICAN NATIONAL STANDARD INSTITUTE (ANSI)

SIZE	L	A	B	C	D	G
8	148	18.9	12.6	4.7	5.7	32
9	154	20.6	15.6	5.8	8.1	46
10	162	21.5	14.4	6.0	8.3	48
11	165	23.0	17.8	6.8	8.5	62
12	174	25.6	18.3	6.9	7.9	70
13	178	26.3	20.3	7.1	8.8	71
14	190	28.9	22.1	7.7	9.6	95
15	205	32.6	24.5	8.5	10.7	124
16	205	32.6	24.5	8.5	10.7	124
17	225	36.3	26.7	8.8	11.0	155
18	248	38.6	28.3	9.2	11.2	176
19	248	38.6	28.3	9.2	11.2	176
5/16	148	18.9	12.6	4.7	5.7	32
3/8	154	21.5	14.4	6.0	8.3	48
7/16	165	23.0	17.8	6.8	8.5	62
1/2	178	26.3	20.3	7.1	8.8	71
9/16	190	28.9	22.1	7.7	9.6	95
5/8	205	32.6	24.5	8.5	10.7	124
11/16	225	36.3	26.7	8.8	11.0	155
3/4	248	38.6	28.3	9.2	11.2	176

美式二代扳手

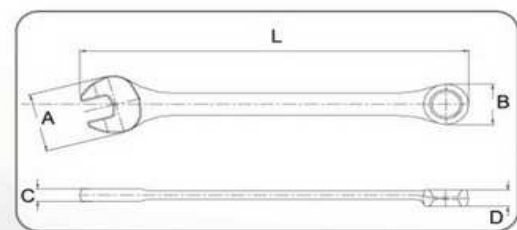

CONFORMS TO AMERICAN NATIONAL STANDARD INSTITUTE (ANSI)

SIZE	L	A	B	C	D	G
6	90	15.7	10.4	4.4	5.0	22
7	98	17.1	12.1	4.5	5.3	24
8	102	19.2	12.8	4.6	5.5	27
9	116	21.2	14.8	5.1	6.2	35
10	123	23.2	16.6	5.1	6.3	52
11	131	24.5	17.3	5.6	6.7	52
12	142	25.4	18.4	5.6	7.1	62
13	148	27.9	20.0	5.7	7.6	67
14	168	30.1	21.7	6.7	8.2	88
15	189	31.7	24.1	7.1	9.1	110
16	189	31.7	24.1	7.1	9.1	110
17	207	36.5	26.7	7.8	9.8	155
18	207	36.5	26.7	7.8	9.8	155
19	230	39.8	29.3	7.8	10.4	185
20	260	43.3	31.5	9.4	11.9	271
21	260	43.3	31.5	9.4	11.9	271
22	280	44.4	33.6	9.6	12.2	286
23	280	44.4	33.6	9.6	12.2	286
24	310	49.0	35.8	10.6	12.4	421
25	333	51.4	37.9	11.0	12.7	476
26	333	51.4	37.9	11.0	12.7	476
27	361	57.1	42.0	11.1	13.1	584
28	361	57.1	42.0	11.1	13.1	584
29	382	59.5	43.7	11.8	13.7	620
30	382	59.5	43.7	11.8	13.7	620
32	412	63.8	48.3	12.1	14.8	781
33	435	66.7	49.3	14.3	18.2	994
34	435	66.7	49.3	14.3	18.2	994
35	455	68	50.4	15.1	19.5	1180
36	490	73.5	54	16.3	20.5	1377
38	490	73.5	54	16.3	20.5	1377
41	545	92	65	16.3	21.8	1880
42	545	92	65	16.3	21.8	1880
43	545	92	65	16.3	21.8	1880
44	545	92	65	16.3	21.8	1880
46	545	92	65	16.3	21.8	1880
48	610	96.8	73	18	22	2583
50	610	96.8	73	18	22	2583
55	630	113	92	21	30	3930
58	630	113	92	21	30	3930
60	630	113	92	21	30	3930

Wrench Series 扳手工具

TR 扳手

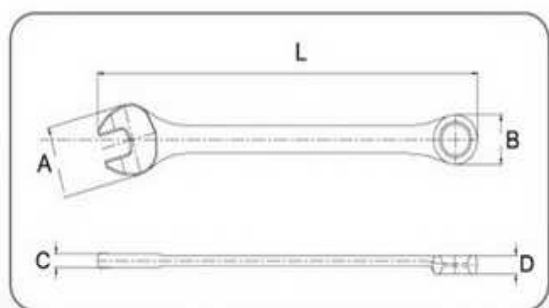

CONFORMS TO AMERICAN NATIONAL
STANDARD INSTITUTE (ANSI)

SIZE	L	A	B	C	D	G
6	128	13.7	10.5	4.3	4.6	21
7	138	15.2	11.6	4.6	5.1	25
8	148	18.9	12.6	4.7	5.7	32
9	154	20.6	15.6	5.8	8.1	46
10	162	21.5	14.4	6.0	8.3	48
11	167	23.0	17.8	6.8	8.5	62
12	174	25.6	18.3	6.9	7.9	70
13	178	26.3	20.3	7.1	8.8	71
14	190	28.9	22.1	7.7	9.6	95
15	205	32.6	24.5	8.5	10.7	124
16	205	32.6	24.5	8.5	10.7	124
17	225	36.3	26.7	8.8	11.0	155
18	248	38.6	28.3	9.2	11.2	176
19	248	38.6	28.3	9.2	11.2	176
20	270	42.5	30.5	9.8	12.4	233
21	270	42.5	30.5	9.8	12.4	233
22	292	46.5	33.3	10.4	12.9	287
23	314	48.5	35.4	10.8	13.9	332
24	314	48.5	35.4	10.8	13.9	332
25	336	50.4	36.5	11.4	14.4	422
26	336	50.4	36.5	11.4	14.4	422
27	359	53.5	38.4	12.3	15.4	512
28	390	57.2	43.1	12.9	15.8	664
29	390	57.2	43.1	12.9	15.8	664
30	390	57.2	43.1	12.9	15.8	664
32	425	62.0	45.1	13.0	16.4	847
1/4	128	13.7	10.5	4.3	4.6	21
5/16	148	18.9	12.6	4.7	5.7	32
3/8	154	20.6	15.6	5.8	8.1	46
7/16	167	23.0	17.8	6.8	8.5	62
1/2	178	26.3	20.3	7.1	8.8	71
9/16	190	28.9	22.1	7.7	9.6	95
5/8	205	32.6	24.5	8.5	10.7	124
11/16	225	36.3	26.7	8.8	11.0	155
3/4	248	38.6	28.3	9.2	11.2	176
13/16	270	42.5	30.5	9.8	12.4	233
7/8	292	46.5	33.3	10.4	12.9	287
15/16	314	48.5	35.4	10.8	13.9	332
1"	336	50.4	36.5	11.4	14.4	422
1-1/16	359	53.5	38.4	12.3	15.4	512
1-1/8	390	57.2	43.1	12.9	15.8	664
1-1/4	425	62.0	45.1	13.0	16.4	847

Wrench Series 扳手工具

加長型棘輪單向扳手

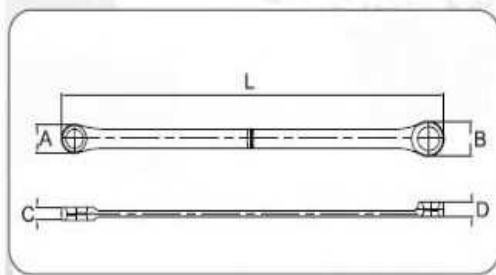
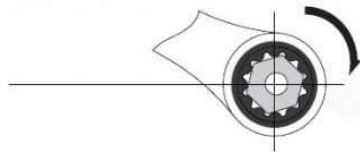

CAR REPAIR

SIZE	L	A	B	C	D	G
8	235	15.9	12.3	6.7	7.3	80
10	292	20.2	14.5	8.0	7.8	124
12	328	23.3	17.3	8.6	10.3	170
13	348	22.9	18.7	8.9	10.6	194
14	368	27.5	20.8	9.3	10.9	230
15	386	26.4	21.1	9.7	12.4	248
17	408	31.8	24.0	10.8	12.4	292
19	420	34.5	26.3	12.3	14.1	410

單向棘輪GW扳手

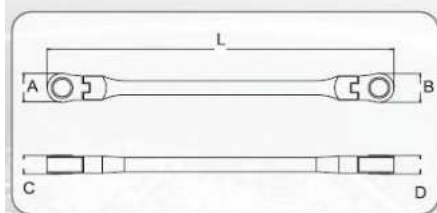
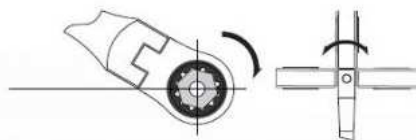

CAR REPAIR

SIZE	L	A	B	C	D	G
8x10	236.6	15.4	18.8	7.4	8.8	221.6
10x11	294.0	18.8	21.3	8.8	9.2	317.2
10x12	294.0	18.8	21.3	8.8	9.2	317.2
11x13	329.7	21.3	26.8	9.2	10.1	401.7
12x14	329.7	21.3	26.8	9.2	10.1	401.7
13x15	369.9	26.8	28.4	10.1	11.6	638.8
14x17	369.9	26.8	28.4	10.1	11.6	638.8
16x18	411.6	28.4	31.0	11.6	13.0	640.4
17x19	411.6	28.4	31.0	11.6	13.0	640.4

Wrench Series 扳手工具

打擊梅花扳手

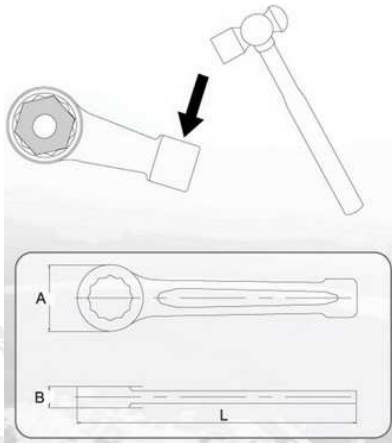

CONFORMS TO DIN 7444 STANDARD

SIZE	L	A	B
24	168	43.4	14.8
27	180	46	16
30	190	51.5	17
32	190	54	17
36	205	58.5	18.5
38	228	64.6	20.1
41	230	65	20
46	240	73.5	22
50	253	78.5	24
55	266	85	25
60	280	92	26
65	300	102	30
70	330	110	33
75	330	110	33
80	340	118	34
85	355	130	36
90	390	142	39
95	390	142	39
100	420	155	43
105	420	155	43
110	450	168	45
115	450	168	45
120	480	182	50
125	480	182	50
130	510	194	57
135	510	194	57
140	520	205	58
145	565	215	58
150	565	215	58

鴉爪

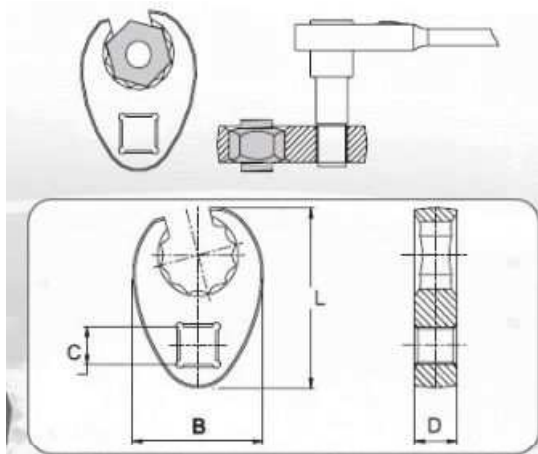

CONFORMS TO AMERICAN NATIONAL STANDARD INSTITUTE

SIZE	L	B	D	C	G
10 (3/8)	36.5	27.7	9.0	3/8"	40
11 (7/16)	36.5	27.7	9.0	3/8"	37
12	36.5	27.7	9.0	3/8"	36
13 (1/2)	36.5	27.7	9.0	3/8"	35
14 (9/16)	41.5	30.3	10.0	3/8"	50
15 (5/8)	41.5	30.3	10.0	3/8"	50
16	41.5	30.3	10.0	3/8"	45
17 (11/16)	45.7	34.2	11.0	3/8"	64
18	45.7	34.2	11.0	3/8"	62
19 (3/4)	45.7	34.2	11.0	3/8"	60
20	53	36.4	12.8	1/2"	77
21	53	36.4	12.8	1/2"	79
22	55.6	38.6	13.2	1/2"	85
23	55.6	38.6	13.2	1/2"	111
24	55.6	38.6	13.2	1/2"	107
25	61	42.5	14	1/2"	107
26	61	42.5	14	1/2"	113
27	61	42.5	14	1/2"	115
28	69.5	49.6	14.5	1/2"	154
29	69.5	49.6	14.5	1/2"	151
30	69.5	49.6	14.5	1/2"	148
32	70	50	14.5	1/2"	142
33	84	55.4	22	3/4"	335
34	84	55.4	22	3/4"	332
35	84	55.4	22	3/4"	324
36	84	55.4	22	3/4"	313
38	91	61.5	23.8	3/4"	493
41	91	61.5	23.8	3/4"	377
46	102	70	25.1	3/4"	519
48	102	70	25.1	3/4"	493

ABERLA[®]

Wrench Series 扳手工具

單搖頭棘輪單向扳手

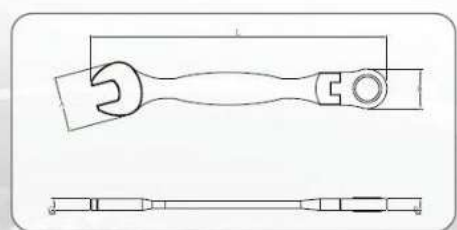
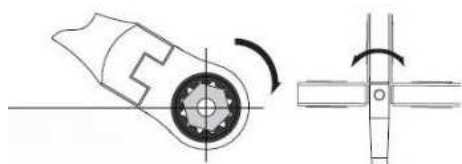

CAR REPAIR

SIZE	L	A	B	C	D	G
8	140	16,7	4,3	4,3	6,6	38,8
9	148	18,0	4,7	4,7	7,3	48,1
10	160	19,6	4,9	4,9	7,9	55,6
11	165	21,1	5,2	5,2	8,2	64,4
12	170	22,2	5,2	5,2	8,5	84,6
13	178	24,1	5,8	5,8	8,8	96,6
14	190	26,4	6,0	6,0	9,2	108,9
15	200	27,7	6,1	6,1	9,7	130,4
16	205	29,2	7,0	7,0	10,3	149,3
17	225	31,0	7,0	7,0	10,8	183,9
18	236	32,0	7,3	7,3	11,0	201,7
19	248	33,0	8,3	8,2	12,2	237,3

雙搖頭棘輪扳手

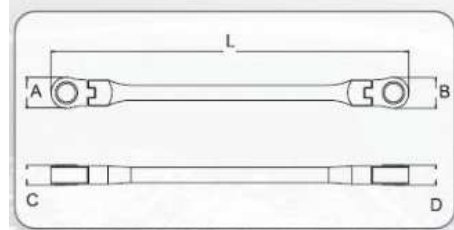
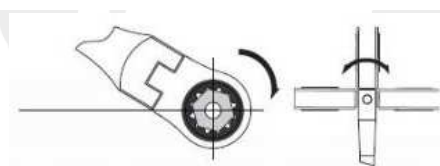

CAR REPAIR

SIZE	L	A	B	C	D	G
8x10	236,6	15,4	18,8	7,4	8,8	221,6
10x11	294,0	18,8	21,3	8,8	9,2	317,2
10x12	294,0	18,8	21,3	8,8	9,2	317,2
11x13	329,7	21,3	26,8	9,2	10,1	401,7
12x14	329,7	21,3	26,8	9,2	10,1	401,7
13x15	369,9	26,8	28,4	10,1	11,6	638,8
14x17	369,9	26,8	28,4	10,1	11,6	638,8
16x18	411,6	28,4	31,0	11,6	13,0	640,4
17x19	411,6	28,4	31,0	11,6	13,0	640,4

Wrench Series 扳手工具

短式棘輪扳手

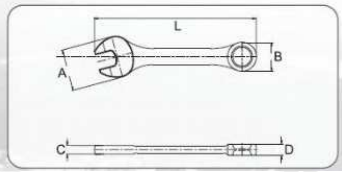
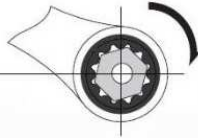

CAR REPAIR

SIZE	L	A	B	C	D	G
8	89	17.3	18.0	4.6	7.5	30
9	92	18.9	18.6	5.3	8.5	37
10	96	21.4	21.4	5.5	8.5	44
11	104	23.7	22.9	5.6	8.8	54
12	107	26.0	24.0	6.0	9.0	62
13	109	27.9	25.9	6.2	10.0	75
14	116	30.2	28.5	6.7	10.4	92
15	120	32.1	30.1	7.5	11.4	113
16	124	34.0	31.0	7.5	11.5	120
17	129	36.4	32.9	8.0	12.0	143
18	132	38.0	33.9	8.3	12.2	147
19	140	40.5	35.8	9.1	13.4	191

加長型雙梅花扳手

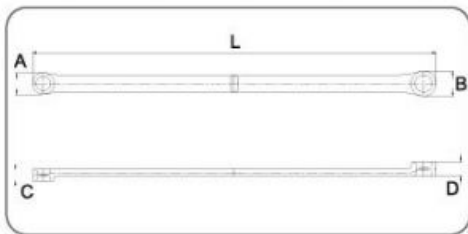

CAR REPAIR

SIZE	L	A	B	C	D	G
8x10	235	12.5	15	7.5	8.4	72
10x11	291	14.3	17	8.5	9.5	95
10x12	291	14.3	17	8.5	9.5	95
11x13	328	17.8	20.3	10.4	11.3	157
12x14	328	17.8	20.3	10.4	11.3	157
13x15	368	20.2	23.3	11.5	13.2	217
14x17	368	20.2	23.3	11.5	13.2	217
16x18	407	23.7	26.6	13	14.8	284
17x19	407	23.7	26.6	13	14.8	284
19x21	415	27.5	29.7	13.46	14.39	376
22x24	430	31.3	34.0	15.4	17.7	482
8 x 10, B12 x 14, B14 x 17, B17 x 19						840

LS特長扳手

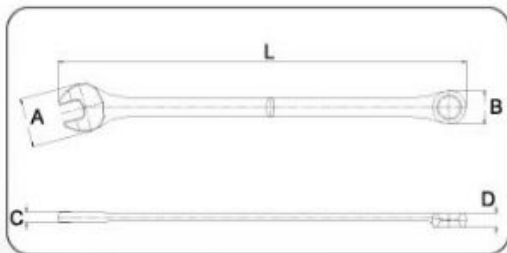

CAR REPAIR

SIZE	L	A	B	C	D	G
10	189	22.8	15.8	5.1	6.9	53
11	207	24.6	17.3	5.3	7.0	62
12	225	27.2	18.8	5.6	7.8	77
13	243	28.6	20.4	5.7	8.5	113
14	261	31.4	21.8	6.9	9.1	128
15	279	33.5	23.4	7	9.3	144
16	297	35.3	24.8	7.3	10.0	182
17	314	37.6	26.2	7.4	10.1	197
18	333	39.4	27.5	7.8	11.3	223
19	349	41.5	28.7	8.7	12.7	271
10 11 12 13 14 15 16 17 18 19						1998