

# 2016 Catalogue Pneumatic tools



P. 09-20

Air Sander  
氣動砂磨機/拋光機



P. 21-28

Impact Wrench  
氣動扳手



P. 29-34

Screwdriver  
氣動螺絲起子



P. 35

Air File  
氣動銼刀機



P. 36-42

Air Hammer  
氣動鎚



P. 43

Air Valve Lapper  
氣門研磨機



P. 44-45

Rivet Nut Tools  
拉帽槍



P. 46

Tapping Tool  
攻牙機



P. 47

Air Drill  
氣鑽

## Index

專業氣動工具製造廠 高效能 高品質 高可靠度

Professional pneumatic tools factory high-performance high quality, high reliability



**P. 48-51**

Air Grinder  
氣動砂輪機



**P. 52-58**

Air Die Grinder  
氣動刻磨機



**P. 58**

Air Beveler  
倒角機



**P. 59**

Air Riveter  
拉釘槍



**P. 60**

Air Spray Gun  
噴漆槍



**P. 61-62**

Air Lubricator  
氣動黃油機



**P. 63**

Torque Wrench  
扭力扳手



**P. 64**

Spring Balancer  
彈簧吊車

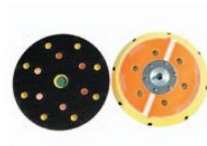

**P. 65-72**

Accessories  
配件



# Air Sander

## Blade :

General type : Bakelite material  
Oil Free type : Engineering plastic

## Vacuum Hose :

Design upon Fluid analysis, high Vacuum efficiency, 360 degree swivel of vacuum connector with 3 sizes : 1", 1-1/8", 1-1/4" for selection.

## 葉片 :

一般型：電木材質  
無油型：工程塑膠

## 集塵管 :

流體分析設計，集塵效率高，集塵管為360度旋轉，有3種尺寸選擇 (1", 1-1/8", 1-1/4")。

## Pneumatic Motor :

FCD45 cast steel with High wear-resistance.

## 馬達 :

FCD45鑄鋼，具有高耐磨特性

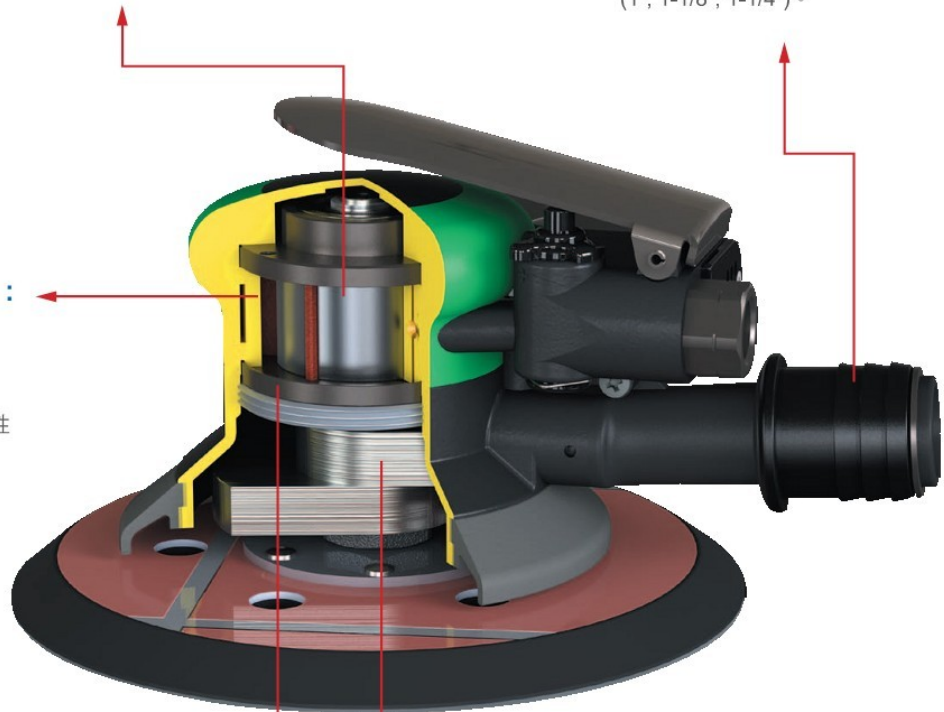

## Rotor :

General type : made from SMF-4030 steel, Heat treatment, with advantage of high wear-resistance.

Oil Free type : Composite materials. High wear-resistance, high strength, allowable under Oil-FreeCircumstances.

## Shaft :

In one-piece structure where precision die-casting eccentric block results in dynamic balance and low noise level.

## 轉子 :

一般型：SMF-4030鋼材，熱處理，具有高耐磨優點。

無油型：複合材料，具高耐磨、高強度之優點，可以使用於不加油之環境下。

## 偏心軸 :

偏心軸為一體成型，具有動平衡設計以及低振動之優點。偏心塊為精密鑄造。



## The coding principle of air sander 氣動研磨機編碼原則

# WS-105SF-5HK

MODEL NO. 機種號碼

Vacuum Mode 集塵模式

N : Non-Vac. 不吸塵

S : Self-Generated Vac. 自吸式

C : Cenreal Vac. 中央吸塵式

F : Ultra Fine Sanding 超精細研磨

(none) (空白) : General Sanding 一般研磨

R : Aggressive Sanding 粗研磨

Kit 套件組

Pad Face 研磨盤底面

H : Hook (Velcro) 黏扣面

V : Vinyl 人造皮面

Pad Diameter 研磨盤直徑

Hook (Velcro)





黏扣面



Vinyl

人造皮面 (自黏)

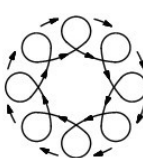

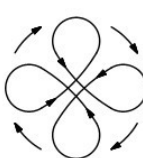
Color-Coded Lever 板機顏色	Abrasive Grit Size 磨料粒度	Orbit Dia. 偏心直徑 inch (mm)
	Ultra Fine Sanding (500+Grit generally) 超精細研磨 (500以上 粒度)	 3/32" (2.5)
	General Sanding (120~400 Grit generally) 一般研磨 (120~140 粒度)	 3/16" (5)
	Aggressive Sanding (under 120 Grit generally) 粗研磨 (120以下 粒度)	 3/8" (9.5)



### 3 in 1 / 三合一 Vacuum Modes 集塵模式轉換



Push flow control valve out with small pole stick (accessories), so can be easy to switch to either of central vacuum, non-vacuum and self-generated vacuum function.

使用配件(圓棒)頂出流向控制栓，可以輕易轉換為中央集塵 / 不吸塵 / 吸塵三種集塵模式。



Model 型號	Pad Dia. 底盤尺寸	Orbit Dia. 偏心直徑	Weight 重量	Noise 噪音值	Packing 包裝明細 (CTN)
	inch	mm	kg	dB (A)	PCS/N.W./G.W./CUFT
WS-1011PF-5H	5"	2.5	0.71	82	12pcs/15.1kg/16.1kg/2.6'
WS-1011P-5H	5"	5	0.74	82	12pcs/15.4kg/16.4kg/2.6'
WS-1011PR-5H	5"	9.5	0.78	82	12pcs/15.8kg/15.8kg/2.6'
WS-1011PF-6H	6"	2.5	0.74	82	12pcs/17.1kg/18.1kg/2.6'
WS-1011P-6H	6"	5	0.78	82	12pcs/16.6kg/17.6kg/2.6'
WS-1011PR-6H	6"	9.5	0.84	82	12pcs/16.8kg/17.8kg/2.6'

### Oil Free 3 in 1 : Vacuum / Central Vacuum / Non Vacuum 無油式三合一：集塵 / 中央集塵 / 不集塵



Model 型號	Pad Dia. 底盤尺寸	Orbit Dia. 偏心直徑	Weight 重量	Noise 噪音值	Packing 包裝明細 (CTN)
	inch	mm	kg	dB (A)	PCS/N.W./G.W./CUFT
WS-1011NF-3H	3"	2.5	0.68	82	12pcs/11kg/12kg/2'
WS-1011N-3H	3"	5	0.70	82	12pcs/12.1kg/13.1kg/2'
WS-1011NF-5H	5"	2.5	0.71	82	12pcs/12.7kg/13.7kg/2'
WS-1011N-5H	5"	5	0.73	82	12pcs/13kg/14kg/2'
WS-1011NR-5H	5"	9.5	0.76	82	12pcs/13.4kg/14.4kg/2'
WS-1011NF-6H	6"	2.5	0.75	82	12pcs/13.2kg/14.2kg/2.6'
WS-1011N-6H	6"	5	0.78	82	12pcs/13.5kg/14.5kg/2.6'
WS-1011NR-6H	6"	9.5	0.82	82	12pcs/14kg/15kg/2.6'

### Oil Free Non Vacuum / 無油式不集塵



Model 型號	Pad Dia. 底盤尺寸	Orbit Dia. 偏心直徑	Weight 重量	Noise 噪音值	Packing 包裝明細 (CTN)
	inch	mm	kg	dB (A)	PCS/N.W./G.W./CUFT
WS-101PF-5H	5"	2.5	0.82	82	12pcs/16.2kg/17.2kg/2.6'
WS-101P-5H	5"	5	0.84	82	12pcs/16.6kg/17.6kg/2.6'
WS-101PR-5H	5"	9.5	0.87	82	12pcs/16.9kg/17.9kg/2.6'
WS-101PF-6H	6"	2.5	0.86	82	12pcs/17.1kg/18.1kg/2.6'
WS-101P-6H	6"	5	0.89	82	12pcs/17.7kg/18.7kg/2.6'
WS-101PR-6H	6"	9.5	0.93	82	12pcs/17.9kg/18.9kg/2.6'

### 3 in 1 : Vacuum / Central Vacuum / Non Vacuum 三合一：集塵 / 中央集塵 / 不集塵



Model 型號	Pad Dia. 底盤尺寸	Orbit Dia. 偏心直徑	Weight 重量	Noise 噪音值	Packing 包裝明細 (CTN)
	inch	mm	kg	dB (A)	PCS/N.W./G.W./CUFT
WS-101NF-3H	3"	2.5	0.68	81	12pcs/11.6kg/12.6kg/2'
WS-101N-3H	3"	5	0.70	81	12pcs/12.7kg/13.7kg/2'
WS-101NF-5H	5"	2.5	0.71	81	12pcs/13.3kg/14.3kg/2'
WS-101N-5H	5"	5	0.73	81	12pcs/13.6kg/14.6kg/2'
WS-101NR-5H	5"	9.5	0.76	81	12pcs/14kg/15kg/2'
WS-101NF-6H	6"	2.5	0.75	81	12pcs/13.8kg/14.8kg/2.6'
WS-101N-6H	6"	5	0.78	81	12pcs/14.1kg/15.1kg/2.6'
WS-101NR-6H	6"	9.5	0.82	81	12pcs/14.6kg/15.6kg/2.6'

### Non Vacuum / 不集塵

- Pad Face / 盤面規格：Hook / Vinyl
- Air Cons. / 工作耗氣量：7 cfm (200 L/min)

- Free Speed / 無負載轉速：11,000rpm
- Air Pressure / 空氣壓力：90 psi (6.2bar)

- Air Inlet / 進氣口尺寸：1/4" PT or NPT
- Min. Hose Size / 進氣管尺寸：1/4" (6.35mm)

## Random Orbital Palm Sander

## WS-1051 Series

Oil Free



Model 型號	Pad Dia. 底盤尺寸	Orbit Dia. 偏心直徑	Weight 重量	Noise 噪音值	Packing 包裝明細 (CTN)
	inch	mm	kg	dB (A)	PCS/N.W./G.W./CUFT
WS-1051SF-3H	3"	2.5	0.59	93	12pcs/11.9kg/12.9kg/2.6'
WS-1051S-3H	3"	5	0.63	93	12pcs/12.4kg/13.4kg/2.6'
WS-1051SF-5H	5"	2.5	0.79	93	12pcs/14.3kg/15.3kg/2.6'
WS-1051S-5H	5"	5	0.80	93	12pcs/14.4kg/15.4kg/2.6'
WS-1051SR-5H	5"	9.5	0.85	93	12pcs/14.9kg/15.9kg/2.6'
WS-1051SF-6H	6"	2.5	0.84	93	12pcs/14.9kg/15.9kg/2.6'
WS-1051S-6H	6"	5	0.85	93	12pcs/15kg/16kg/2.6'
WS-1051SR-6H	6"	9.5	0.90	93	12pcs/15.5kg/16.5kg/2.6'

### Oil Free Self Vacuum / 無油式集塵



Model 型號	Pad Dia. 底盤尺寸	Orbit Dia. 偏心直徑	Weight 重量	Noise 噪音值	Packing 包裝明細 (CTN)
	inch	mm	kg	dB (A)	PCS/N.W./G.W./CUFT
WS-1051CF-3H	3"	2.5	0.59	80	12pcs/11.9kg/12.9kg/2.6'
WS-1051C-3H	3"	5	0.63	80	12pcs/12.4kg/13.4kg/2.6'
WS-1051CF-5H	5"	2.5	0.79	80	12pcs/14.3kg/15.3kg/2.6'
WS-1051C-5H	5"	5	0.80	80	12pcs/14.4kg/15.4kg/2.6'
WS-1051CR-5H	5"	9.5	0.85	80	12pcs/14.9kg/15.9kg/2.6'
WS-1051CF-6H	6"	2.5	0.84	80	12pcs/14.9kg/15.9kg/2.6'
WS-1051C-6H	6"	5	0.85	80	12pcs/15kg/16kg/2.6'
WS-1051CR-6H	6"	9.5	0.90	80	12pcs/15.5kg/16.5kg/2.6'

### Oil Free Central Vacuum / 無油式中央集塵



Model 型號	Pad Dia. 底盤尺寸	Orbit Dia. 偏心直徑	Weight 重量	Noise 噪音值	Packing 包裝明細 (CTN)
	inch	mm	kg	dB (A)	PCS/N.W./G.W./CUFT
WS-1051NF-3HA	3"	2.5	0.61	75	12pcs/11.5kg/12.5kg/2'
WS-1051N-3HA	3"	5	0.70	75	12pcs/12.6kg/13.6kg/2'
WS-1051NF-5H	5"	2.5	0.72	75	12pcs/12.7kg/13.7kg/2'
WS-1051N-5H	5"	5	0.73	75	12pcs/12.8kg/12.9kg/2'
WS-1051NR-5H	5"	9.5	0.78	75	12pcs/13.7kg/14.7kg/2'
WS-1051NF-6H	6"	2.5	0.77	75	12pcs/13.3kg/14.3kg/2'
WS-1051N-6H	6"	5	0.78	75	12pcs/13.7kg/14.7kg/2'
WS-1051NR-6H	6"	9.5	0.83	75	12pcs/13.8kg/14.8kg/2'

### Oil Free Non Vacuum / 無油式不集塵



Standard / 標準



Muffle Cover  
排氣蓋

Option / 選配



Swivel Exhaust  
排氣管

Non Vacuum Series :

Swivel Exhaust is optional instead of standard Muffle Cover  
Exhaust Direction can be easy to change.

不集塵系列 :

排氣蓋可選擇使用可360度旋轉的排氣管。  
排氣方向可任意調節。

- Pad Face / 盤面規格 : Hook / Vinyl
- Air Inlet / 進氣口尺寸 : 1/4" PT or NPT

- Free Speed / 無負載轉速 : 12,000rpm
- Min. Hose Size / 進氣管尺寸 : 1/4" (6.35mm)

- Air Cons. / 工作耗氣量 : 6 cfm (170 L/min)
- Air Pressure / 空氣壓力 : 90 psi (6.2bar)



Model 型號	Pad Dia. 底盤尺寸	Orbit Dia. 偏心直徑	Weight 重量	Noise 噪音值	Packing 包裝明細 (CTN)
	inch	mm	kg	dB (A)	PCS/N.W./G.W./CUFT
WS-105SF-3H	3"	2.5	0.70	95	12pcs/13.2kg/14.2kg/2.6'
WS-105S-3H	3"	5	0.72	95	12pcs/13.4kg/14.4kg/2.6'
WS-105SF-5H	5"	2.5	0.86	95	12pcs/15.2kg/16.2kg/2.6'
WS-105S-5H	5"	5	0.91	95	12pcs/15.6kg/16.6kg/2.6'
WS-105SR-5H	5"	9.5	0.95	95	12pcs/16.1kg/17.1kg/2.6'
WS-105SF-6H	6"	2.5	0.92	95	12pcs/15.7kg/16.7kg/2.6'
WS-105S-6H	6"	5	0.96	95	12pcs/16kg/17kg/2.6'
WS-105SR-6H	6"	9.5	1.00	95	12pcs/16.8kg/17.8kg/2.6'

### Self Vacuum / 集塵



Model 型號	Pad Dia. 底盤尺寸	Orbit Dia. 偏心直徑	Weight 重量	Noise 噪音值	Packing 包裝明細 (CTN)
	inch	mm	kg	dB (A)	PCS/N.W./G.W./CUFT
WS-105CF-3H	3"	2.5	0.70	78	12pcs/13.2kg/14.2kg/2.6'
WS-105C-3H	3"	5	0.72	78	12pcs/13.4kg/14.4kg/2.6'
WS-105CF-5H	5"	2.5	0.87	78	12pcs/15.2kg/16.2kg/2.6'
WS-105C-5H	5"	5	0.91	78	12pcs/15.6kg/16.6kg/2.6'
WS-105CR-5H	5"	9.5	0.94	78	12pcs/16.1kg/17.1kg/2.6'
WS-105CF-6H	6"	2.5	0.92	78	12pcs/15.7kg/16.7kg/2.6'
WS-105C-6H	6"	5	0.95	78	12pcs/16kg/17kg/2.6'
WS-105CR-6H	6"	9.5	1.00	78	12pcs/16.8kg/17.8kg/2.6'

### Central Vacuum / 中央集塵



Model 型號	Pad Dia. 底盤尺寸	Orbit Dia. 偏心直徑	Weight 重量	Noise 噪音值	Packing 包裝明細 (CTN)
	inch	mm	kg	dB (A)	PCS/N.W./G.W./CUFT
WS-105NF-3HA	3"	2.5	0.72	75	12pcs/12.8kg/13.8kg/2'
WS-105N-3HA	3"	5	0.81	75	12pcs/13kg/14kg/2'
WS-105NF-5H	5"	2.5	0.82	75	12pcs/13.7kg/14.7kg/2'
WS-105N-5H	5"	5	0.84	75	12pcs/14kg/15kg/2'
WS-105NR-5H	5"	9.5	0.87	75	12pcs/14.4kg/15.4kg/2'
WS-105NF-6H	6"	2.5	0.86	75	12pcs/14.2kg/15.2kg/2'
WS-105N-6H	6"	5	0.89	75	12pcs/14.8kg/15.8kg/2'
WS-105NR-6H	6"	9.5	0.93	75	12pcs/15.2kg/16.2kg/2'

### Non Vacuum / 不集塵



Model 型號	Pad Dia. 底盤尺寸	Orbit Dia. 偏心直徑	Weight 重量	Noise 噪音值	Packing 包裝明細 (CTN)
	inch	mm	kg	dB (A)	PCS/N.W./G.W./CUFT
WS-105N2-5H	5"	5	0.84	75	12pcs/14kg/15kg/2'

### Special for Sponge W/ Wax / 需搭配6吋海綿使用的打蠟機

- Pad Face / 盤面規格 : Hook / Vinyl
- Air Inlet / 進氣口尺寸 : 1/4" PT or NPT
- Free Speed / 無負載轉速 : 12,000rpm
- Min. Hose Size / 進氣管尺寸 : 1/4" (6.35mm)
- Air Cons. / 工作耗氣量 : 6 cfm (170 L/min)
- Air Pressure / 空氣壓力 : 90 psi (6.2bar)



# Jitterbug & Delta Sander

## WS-102 Series

Elastic mechanism for durability and long lifespan.  
Patent in Taiwan, U.S.A., and China.

針對耐久性而研發的彈性裙構造，壽命超長。  
台灣、美國、大陸專利。



WS-102JC-V



WS-102J-H



WS-102T-H



WS-102JP-H



WS-102TP-H

Model 型號	Pad Dia. 底盤尺寸 mm	Orbit Dia. 偏心直徑 mm	Vac. Mode 集塵模式	Pad Face 盤片規格 Vinyl / Hook	Weight 重量 kg	Noise 噪音值 dB (A)	Packing 包裝明細 (CTN) PCS/N.W./G.W./CUFT
WS-102JC-V	100 x 110	2.5	Non. Vac.	Vinyl / Hook	0.91	77	12pcs/14kg/15kg/2'
WS-102J-H	100 x 110	5	Non. Vac.	Vinyl / Hook	0.81	77	12pcs/13.4kg/14.4kg/2'
WS-102T-H	125 x 95	5	Non. Vac.	Vinyl / Hook	0.81	77	12pcs/13.4kg/14.4kg/2'
WS-102JP-H	100 x 110	5	3-in-1	Hook	0.82	84.1	12pcs/16.5kg/17.5kg/2.6'
WS-102TP-H	125 x 95	5	3-in-1	Hook	0.82	84.1	12pcs/16.5kg/17.5kg/2.6'

- Air Inlet / 進氣口尺寸: 1/4" PT or NPT
- Min. Hose Size / 進氣管尺寸: 1/4" (6.35mm)

- Free Speed / 無負載轉速: 10,000rpm
- Air Pressure / 空氣壓力: 90 psi (6.2bar)

- Air Cons. / 工作耗氣量: 7 cfm (200 L/min)

## WX-121/WX-122 Series

Both hands operation is good way to get better sand rubbing.

雙手操作可以得到較佳的研磨表面。



WX-121CL



WX-122

Model 型號	Pad Dia. 底盤尺寸 mm	Orbit Dia. 偏心直徑 mm	Vac. Mode 集塵模式	Free Speed 無負載轉速 RPM	Weight 重量 kg	Noise 噪音值 dB (A)	Packing 包裝明細 (CTN) PCS/N.W./G.W./CUFT
WX-121CL	176 x 93	5	Vac.	7,000	2.24	92.7	6pcs/19.3kg/20.3kg/3.13'
WX-121L	176 x 93	5	Non. Vac.	7,000	2.24	92.7	6pcs/19.3kg/20.3kg/3.13'
WX-122C	220 x 112	5	Vac.	6,500	2.27	97.3	6pcs/19.6kg/20.6kg/3.13'
WX-122	220 x 112	5	Non. Vac.	6,500	2.27	97.3	6pcs/19.6kg/20.6kg/3.13'

- Air Inlet / 進氣口尺寸: 1/4" PT or NPT
- Pad Face / 盤面規格: Hook / Vinyl

- Min. Hose Size / 進氣管尺寸: 1/4" (6.35mm)
- Air Pressure / 空氣壓力: 90 psi (6.2bar)

- Air Cons. / 工作耗氣量: 14 cfm (400 L/min)

# Jitterbug Sander

## WS-108 Series

3-2/3" x 7"



108NF



WS-108CF / 108SF

Model 型號	Pad Dia. 底盤尺寸	Orbit Dia. 偏心直徑	Vac. Mode 集塵模式	Weight 重量	Noise 噪音值	Packing 包裝明細 (CTN)
	inch (mm)	mm		kg	dB (A)	PCS/N.W./G.W./CUFT
WS-108NF	3-2/3" x 7" (93 x 178)	2.5	Non-Vac.	1.1	77.7	12pcs/17.3kg/18.3kg/2.6'
WS-108CF	3-2/3" x 7" (93 x 178)	2.5	Central Vac.	1.2	77.7	12pcs/19.2kg/20.2kg/2.6'
WS-108SF	3-2/3" x 7" (93 x 178)	2.5	Self Vac.	1.2	77.7	12pcs/19.2kg/20.2kg/2.6'

## WS-133 Series

3" x 4"



WS-133N



WS-133C / 133S

Durable anti-vibration shoe support.  
高壽命防震柱設計。

Model 型號	Pad Dia. 底盤尺寸	Orbit Dia. 偏心直徑	Vac. Mode 集塵模式	Weight 重量	Noise 噪音值	Packing 包裝明細 (CTN)
	inch (mm)	mm		kg	dB (A)	PCS/N.W./G.W./CUFT
WS-133N	3" x 4" (75 x 100)	3	Non-Vac.	0.75	95	12pcs/12.4kg/13.4kg/2'
WS-133C	3" x 4" (75 x 100)	3	Central Vac.	0.8	95	12pcs/14.3kg/15.3kg/2.6'
WS-133S	3" x 4" (75 x 100)	3	Self Vac.	0.8	95	12pcs/14.3kg/15.3kg/2.6'

## WS-1331 Series

3" x 4" OIL FREE



WS-1331N



WS-1331C / 1331S

Durable anti-vibration shoe support.  
高壽命防震柱設計。

Model 型號	Pad Dia. 底盤尺寸	Orbit Dia. 偏心直徑	Vac. Mode 集塵模式	Weight 重量	Noise 噪音值	Packing 包裝明細 (CTN)
	inch (mm)	mm		kg	dB (A)	PCS/N.W./G.W./CUFT
WS-1331N	3" x 4" (75 x 100)	3	Non-Vac.	0.7	75.1	12pcs/10.6kg/11.6kg/2'
WS-1331C	3" x 4" (75 x 100)	3	Central Vac.	0.75	75.1	12pcs/12.5kg/13.5kg/2.6'
WS-1331S	3" x 4" (75 x 100)	3	Self Vac.	0.75	75.1	12pcs/12.5kg/13.5kg/2.6'

- Air Inlet / 進氣口尺寸 : 1/4" PT or NPT
- Pad Face / 盤面規格 : Hook / Vinyl

- Min. Hose Size / 進氣管尺寸 : 1/4" (6.35mm)
- Air Pressure / 空氣壓力 : 90 psi (6.2bar)

- Air Cons. / 工作耗氣量 : 6 cfm (170 L/min)
- Free Speed / 無負載轉速 : 10,000rpm

# Belt Sander

## WS-103 Series

Handle angle can adjusting range reach 180°.  
Adjustable guide shaft.  
Handle rear can be connected with muffle tube and protect work piece surface won't be oil pollution.

握把角度可調整範圍達180°。  
可調式的定位導桿。  
手柄後方可接消音管降低噪音，且保護工件表面不會被油污染。



WS-103 / 103H



WS-103L



WS-104



Model 型號	Belt Size 砂布帶尺寸 mm	Belt Speed 砂布帶速度 m / min	Free Speed 無負載轉速 RPM	Length 長度 mm	Air Cons. 工作耗氣量 cfm (l/min)	Weight 重量 kg	Noise 噪音值 dB (A)	Packing 包裝明細 (CTN) PCS/N.W./G.W./CUFT
WS-103	60 x 260	1,100	7,000	210	8.8 (250)	1.1	83.7	12pcs/20kg/21kg/2.6'
WS-103L	100 x 260	1,100	7,000	210	8.8 (250)	1.4	83.7	8pcs/18kg/19kg/2.6'
WS-103H	60 x 260	2,250	15,000	210	8.8 (250)	1.1	83.7	12pcs/20kg/21kg/2.6'
WS-104	50 x 235	1,700	9,000	223	7.7 (220)	0.76	91.2	10pcs/9.3kg/10.3kg/1'

## WX-125/WX-126/WX-127

Easy for any angle work areas of sand rubbing.  
Rear exhaust to reduce dust and low noise.

適合平面、曲面與各個角度的研磨。  
後方排氣可減少粉塵與噪音。



WX-127



WX-126



WX-125

Model 型號	Belt Size 砂布帶尺寸 mm	Belt Speed 砂布帶速度 m / min	Free Speed 無負載轉速 RPM	Length 長度 mm	Air Cons. 工作耗氣量 cfm (l/min)	Weight 重量 kg	Noise 噪音值 dB (A)	Packing 包裝明細 (CTN) PCS/N.W./G.W./CUFT
WX-125	10 x 330	1,301	18,000	280	9.3 (260)	0.81	85	20pcs/18kg/19kg/1.4'
WX-126	20 x 520	2,743	18,000	350	10.3 (290)	1.1	84	10pcs/13.2kg/14.2kg/1.4'
WX-127	30 x 540	2,042	13,000	390	10.3 (290)	2.1	85	6pcs/14kg/15kg/2.5'

• Air Inlet / 進氣口尺寸 : 1/4" PT or NPT

• Min. Hose Size / 進氣管尺寸 : 1/4" (6.35mm)

• Air Pressure / 空氣壓力 : 90 psi (6.2bar)



# Detailing Tools

## WS-111/WS-112 Series

With Regulator, easy to adjust speed  
Rear exhaust.

附流量調節器，可依使用需求調整適當的轉速  
後排氣設計。



### OPTION 選配件



purchase the proper type of screw converter to the specification of your pad

可選購合適的轉接螺絲以接母牙底盤

Screw Converter / 轉接螺絲

1. 311020110 -5/16-24UNF + M6
2. 311020100 -5/16-24UNF + 1/4-20 UNC



WS-111 / 111F / 111R



WS-112



WS-112R -Roloc Type

### WS-112R

Contents :

1. Mini Disc Sander x 1pc
2. Roloc Backing Pad x 1pc
3. Roloc Surface Conditioning Disc - Coarse #80 x1pc
4. Roloc Surface Conditioning Disc - Medium #150 x 1pc
5. Roloc Surface Conditioning Disc - Fine #300 x 1pc
6. Roloc Sanding Disc - #80 grit x 1pc

Model 型號	Pad Dia. 底盤尺寸	Orbit Dia 偏心直徑	Free Speed 無負載轉速	Length 長度	Height 高度	Weight 重量	Air Cons. 工作耗氣量	Noise 噪音值	Packing 包裝明細 (CTN)
	inch	mm	RPM	mm	mm	kg	cfm (l/min)	dB (A)	PCS/N.W./G.W./CUFT
WS-111	2" or 3"	1.5	18,000	176	95	0.65	7 (200)	88.7	10pcs/8.3kg/9.3kg/0.83'
WS-111F	2" or 3"	0.75	18,000	176	95	0.65	7 (200)	88.7	10pcs/8.3kg/9.3kg/0.83'
WS-111R	2" or 3"	3	18,000	176	95	0.65	7 (200)	88.7	10pcs/8.3kg/9.3kg/0.83'
WS-112	2" or 3"	N/A	18,000	176	99	0.59	7 (200)	88.5	10pcs/8kg/9kg/0.83'
WS-112R	2" or 3"	N/A	18,000	176	106	0.59	7 (200)	88.5	10pcs/9kg/10kg/0.9'



WX-114 / 114H / 114L



WX-118-2 / 118-3

Model 型號	Pad Dia. 底盤尺寸	Orbit Dia 偏心直徑	Free Speed 無負載轉速	Length 長度	Height 高度	Weight 重量	Air Cons. 工作耗氣量	Noise 噪音值	Packing 包裝明細 (CTN)
	inch or mm	mm	RPM	mm	mm	kg	cfm (l/min)	dB (A)	PCS/N.W./G.W./CUFT
WX-114	30 mm	1.5	7,500	162	75	0.62	7 (200)	74.9	20pcs/12.5kg/13.5kg/0.78'
WX-114H	30 mm	1.5	12,000	162	75	0.62	7 (200)	74.9	20pcs/12.5kg/13.5kg/0.78'
WX-114L	30 mm	1.5	5,500	162	75	0.62	7 (200)	74.9	20pcs/12.5kg/13.5kg/0.78'
WX-118-2	2"	3	15,000	168	75	0.7	1.87 (83)	87.9	20pcs/17.2kg/17.8kg/0.73'
WX-118-3	3"	3	15,000	168	75	0.7	1.87 (83)	87.9	20pcs/17.2kg/17.8kg/0.73'

# Finger Sander

## WS-113 Series



WS-113A / 113AF

311321300  
Hook Face / 黏扣面

311321200  
Rubber Face / 橡膠面

311321100  
Stainless Face / 不銹鋼面



WS-113B / 113BF

With Regulator, easy to adjust speed  
Rear exhaust.

附流量調節器，可依使用需求調整適當的轉速。  
後排氣設計。

Model 型號	Pad Dia. 底盤尺寸	Orbit Dia 偏心直徑	Free Speed 無負載轉速	Length 長度	Height 高度	Weight 重量	Air Cons. 工作耗氣量	Noise 噪音值	Packing 包裝明細 (CTN)
	mm	mm	RPM	mm	mm	kg	cfm (l/min)	dB (A)	PCS/N.W./G.W./CUFT
WS-113A	40 x 50	3	18,000	220	95	0.77	7 (200)	84.9	10pcs/8.7kg/9.7kg/0.9'
WS-113AF	40 x 50	1.5	18,000	220	95	0.77	7 (200)	84.9	10pcs/8.7kg/9.7kg/0.9'
WS-113B	17 x 65	3	18,000	220	95	0.77	7 (200)	84.9	10pcs/8.7kg/9.7kg/0.9'
WS-113BF	17 x 65	1.5	18,000	220	95	0.77	7 (200)	84.9	10pcs/8.7kg/9.7kg/0.9'

• Air Inlet / 進氣口尺寸 : 1/4" PT or NPT

• Min. Hose Size / 進氣管尺寸 : 1/4" (6.35mm)

• Air Pressure / 空氣壓力 : 90 psi (6.2bar)

## WS-106 Series

Alloy Steel gear is more durably after precise process and heat treatment.  
Suitable for the works of ultra meticulous sand rubbing, surface polishing, etc.

合金鋼齒輪組經精密加工並熱處理強化，耐用性超群。  
適用於超精細砂磨、錶面拋光等作業。



WS-106N-1V

WS-106N-3H

WS-106N-5H

### WS-106K

Contents :

1. Mini Polisher x 1
2. 3" Foam Polishing Pad/3"泡棉 x 1
3. 3" Synthetic Wool Buffs/3" 羊毛輪 x1
4. Wrench/板手 x 3 (14.19.22mm)
5. 1-1/4" PAD/1-1/4" 底盤 x 1
6. Adapter/偏心座組合 x1
7. 3"PAD / 3" 底盤 x 1

Packing / 包裝明細 :

12pcs / 16.2kg / 17.2kg / 2.6'

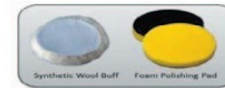

Model 型號	Pad Dia. 底盤尺寸	Pad Face 盤面規格	Orbit Dia 偏心直徑	Free Speed 無負載轉速	Weight 重量	Air Cons. 工作耗氣量	Noise 噪音值	Packing 包裝明細 (CTN)
WS-106N-1V	1-1/4"	Vinyl / Hook	5	2,400	0.83	6.7 (190)	77.5	12pcs/N.W./G.W./CUFT
WS-106N-3H	3"	Hook	N/A	2,400	0.74	6.7 (190)	77.5	12pcs/13.8kg/14.8kg/2.6'
WS-106N-5H	5"	Hook	N/A	2,400	0.8	6.7 (190)	77.5	12pcs/14.5kg/15.5kg/2.6'

• Air Inlet / 進氣口尺寸 : 1/4" PT or NPT

• Min. Hose Size / 進氣管尺寸 : 1/4" (6.35mm)

• Air Pressure / 空氣壓力 : 90 psi (6.2bar)

## WS-110 Series

With Regulator, easy to adjust speed,  
Rear exhaust

附流量調節器，可依使用需求調整適當的轉速  
後排氣設計。



WS-110 / 110H



WS-110R / 110HR  
Roloc Type

### OPTION 選配件



purchase the proper type of screw converter  
to the specification of your pad

可選購合適的轉接螺絲以便接母牙底盤

Screw Converter / 轉接螺絲

1. 311020110 -5/16-24UNF + M6
2. 311020100 -5/16-24UNF + 1/4-20 UNC

### WS-110R / WS-110HR

Contents :

1. Mini Disc Sander x 1pc
2. Roloc Backing Pad x 1pc
3. Roloc Surface Conditioning Disc - Coarse #80 x1pc
4. Roloc Surface Conditioning Disc - Medium #150 x 1pc
5. Roloc Surface Conditioning Disc - Fine #300 x 1pc
6. Roloc Sanding Disc - #80 grit x 1pc

Model 型號	Pad Dia. 底盤尺寸	Free Speed 無負載轉速	Length 長度	Height 高度	Weight 重量	Air Cons. 工作耗氣量	Noise 噪音值	Packing 包裝明細 (CTN)
WS-110	2" or 3"	3,000	187	121.5	0.8	7 (200)	90.8	10pcs/10kg/11kg/0.83'
WS-110R	2" or 3"	3,000	187	132	0.8	7 (200)	90.8	10pcs/11kg/12kg/0.9'
WS-110H	2" or 3"	4,500	187	121.5	0.8	7 (200)	90.8	10pcs/10kg/11kg/0.83'
WS-110HR	2" or 3"	4,500	187	132	0.8	7 (200)	90.8	10pcs/11kg/12kg/0.9'

• Air Inlet / 進氣口尺寸 : 1/4" PT or NPT

• Air Pressure / 空氣壓力 : 90 psi (6.2bar)

• Min. Hose Size / 進氣管尺寸 : 1/4" (6.35mm)

• Orbit Dia / 偏心直徑 : N/A

## WX-116 Series



WX-116 / 116H

Rear exhaust.

後排氣設計。

Model 型號	Pad Dia. 底盤尺寸	Free Speed 無負載轉速	Length 長度	Height 高度	Weight 重量	Air Cons. 工作耗氣量	Noise 噪音值	Packing 包裝明細 (CTN)
	inch	RPM	mm	mm	kg	cfm (l/min)	dB (A)	PCS/N.W./G.W./CUFT
WX-116	3"	2,300	248	54	1.1	2 (57)	88.5	20pcs/25kg/26kg/0.92'
WX-116H	3"	3,200	248	54	1.1	2 (57)	88.5	20pcs/25kg/26kg/0.92'

- Air Inlet / 進氣口尺寸 : 1/4" PT or NPT
- Orbit Dia / 偏心直徑 : N/A

- Air Pressure / 空氣壓力 : 90 psi (6.2bar)

- Min. Hose Size / 進氣管尺寸 : 1/4" (6.35mm)

## WX-1412 Series



WX-1412 / 1412S

Soft-grip handle can be positioned for right or left hand operation.

Variable speed safety-lock lever throttle adjust the speed during operation.

Insulated handle absorbs vibration and reduces cold air transmission to the operator.

軟式把手可調整左右使用方向。

可變速安全板機，操作時可調節速度。

絕緣材質握把可吸收震動力並降低冷空氣對使用者造成的影響。

Model 型號	Pad Dia. 底盤尺寸	Free Speed 無負載轉速	Length 長度	Height 高度	Weight 重量	Air Cons. 工作耗氣量	Noise 噪音值	Packing 包裝明細 (CTN)
	inch	RPM	mm	mm	kg	cfm (l/min)	dB (A)	PCS/N.W./G.W./CUFT
WX-1412	5"-8"	2,500	310	111	2.2	3 (85)	83	10pcs/25.1kg/26.1kg/2.3'
WX-1412S	5"-8"	4,500	310	111	2.2	3 (85)	83	10pcs/25.1kg/26.1kg/2.3'

- Air Inlet / 進氣口尺寸 : 1/4" PT or NPT
- Orbit Dia / 偏心直徑 : N/A

- Air Pressure / 空氣壓力 : 90 psi (6.2bar)

- Min. Hose Size / 進氣管尺寸 : 3/8" (9.5mm)

## WX-117 Series

### Economy 經濟型



WX-117 / 117P

Can be used with Sanding paper, Synthetic Wool Buffs and Sponge.

可搭配砂紙、羊毛輪、泡棉使用。

Model 型號	Pad Dia. 底盤尺寸	Free Speed 無負載轉速	Length 長度	Height 高度	Weight 重量	Air Cons. 工作耗氣量	Noise 噪音值	Packing 包裝明細 (CTN)
	inch	RPM	mm	mm	kg	cfm (l/min)	dB (A)	PCS/N.W./G.W./CUFT
WX-117	7"	4,500	320	99.5	2.25	6 (170)	85	6pcs/16kg/17kg/1.75'
WX-117P	7"	2,800	320	99.5	2.25	6 (170)	85	6pcs/16kg/17kg/1.75'

- Air Inlet / 進氣口尺寸 : 1/4" PT or NPT
- Spindle Thread Size / 螺牙尺寸 : 5/8 x 11UNF

- Min. Hose Size / 進氣管尺寸 : 1/4" (6.35mm)
- Air Pressure / 空氣壓力 : 90 psi (6.2bar)

- Orbit Dia / 偏心直徑 : N/A



# Abrasive Finishing Tool

## WX-173 Series

(Governor)



WX-173LW

W = Wheel / 輪子 LW = Long Arbor + Wheel / 長軸 + 輪子

Model 型號	Vac. Mode 集塵模式	Free Speed 無負載轉速 RPM	Length 長度 mm	Air Cons. 工作耗氣量 cfm (l/min)	Weight 重量 kg	Noise 噪音值 dB (A)	Packing 包裝明細 (CTN) PCS/N.W./G.W./CUFT
WX-173	Non. Vac.	3,400	344	4.2 (118)	1.84	85	10pcs/20kg/21kg/1.1'
WX-173W	Non. Vac.	3,400	394.5	4.2 (118)	2.68	85	5pcs/16.5kg/17kg/1.1'(含輪子)
WX-173LW	Non. Vac.	3,400	478	4.2 (118)	2.89	85	5pcs/16.5kg/17kg/1.1'(含輪子)

• Air Inlet / 進氣口尺寸 : 3/8" PT or NPT

• Min. Hose Size / 進氣管尺寸 : 3/8" (9.5mm)

• Air Pressure / 空氣壓力 : 90 psi (6.2bar)

## WX-172 Series

Needle bearing design for durable application

Working for stainless steel /aluminum /carbon steel /plastic /composite /fiberglass /wood and more.

Remove rust, oxide and scale; clean welds, remove paint and surface condition using abrasive flap wheels.

滾針軸承設計，堅固耐用的應用：

工作不銹鋼/鋁/碳鋼/塑料/複合/玻璃纖維/木等。

除去鐵鏽、氧化物和碎屑以及清潔焊渣，用研磨輪去除油漆和表面狀態。



WX-172ALG

WX-172CLG

NOT including Flap Wheels  
標準出貨不包含百葉輪

ALG = Adaptor Longer Grinder, CLG = Collet Longer Grinder

Model 型號	Collet Size 夾頭尺寸 inch (mm)	Free Speed 無負載轉速 RPM	Length 長度 mm	Air Cons. 工作耗氣量 cfm (l/min)	Weight 重量 kg	Noise 噪音值 dB (A)	Packing 包裝明細 (CTN) PCS/N.W./G.W./CUFT
WX-172ALG	N/A	4,500	309	3 (85)	1.1	88.8	10pcs/11kgs/11.5kgs/1.1'
WX-172CLG	1/4" (6mm)	4,500	285	3 (85)	1	87.3	10pcs/10kgs/10.5kgs/1.1'

• Air Inlet / 進氣口尺寸 : 1/4" PT or NPT

• Min. Hose Size / 進氣管尺寸 : 3/8" (9.5mm)

• Air Pressure / 空氣壓力 : 90 psi (6.2bar)



WX-174

NOT including Flap Wheels  
標準出貨不包含百葉輪

Model 型號	Wheel Size 輪子尺寸 mm	Free Speed 無負載轉速 RPM	Length 長度 mm	Air Cons. 工作耗氣量 cfm (l/min)	Weight 重量 kg	Noise 噪音值 dB (A)	Packing 包裝明細 (CTN) PCS/N.W./G.W./CUFT
WX-174	120 x 100	3,000	406	6 (170)	2.88	85	6pcs/19.8kgs/20.8kgs/1.75'

• Air Inlet / 進氣口尺寸 : 1/4" PT or NPT

• Min. Hose Size / 進氣管尺寸 : 3/8" (9.5mm)

• Air Pressure / 空氣壓力 : 90 psi (6.2bar)

# Air Impact Wrench

## HAMMER MECHANISM INTRODUCTION 錘打結構說明



**TWIN HAMMER MECHANISM**  
雙環結構

作業速度 Working Efficiency  
輸出軸震動值 Anvil Vibration  
運轉震動 Vibration  
耐久性 Endurance  
扭力輸出 Torque output  
(外圍表示較優良)

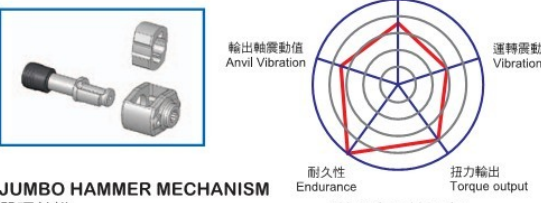

**JUMBO HAMMER MECHANISM**  
單環結構

作業速度 Working Efficiency  
輸出軸震動值 Anvil Vibration  
運轉震動 Vibration  
耐久性 Endurance  
扭力輸出 Torque output  
(外圍表示較優良)

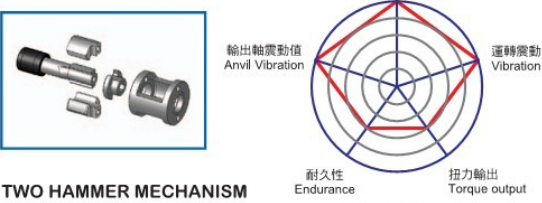

**TWO HAMMER MECHANISM**  
雙錘打塊結構

作業速度 Working Efficiency  
輸出軸震動值 Anvil Vibration  
運轉震動 Vibration  
耐久性 Endurance  
扭力輸出 Torque output  
(外圍表示較優良)

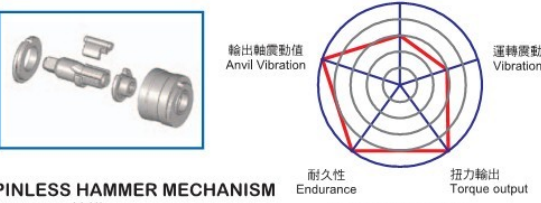

**PINLESS HAMMER MECHANISM**  
PINLESS結構

作業速度 Working Efficiency  
輸出軸震動值 Anvil Vibration  
運轉震動 Vibration  
耐久性 Endurance  
扭力輸出 Torque output  
(外圍表示較優良)

## Mini Impact Wrench

### 3/8" & 1/2" Impact Wrench

Tease Trigger, Handle Exhaust  
6 Position Power regulator: 3 settings in forward, 3 in reverse.  
Blade with spring mounted to prevent dead-lock or power-less problem.

無段式板機，握柄下方排氣。  
6段式扭力調節，正、逆轉各3段。  
葉片彈簧裝置設計，使葉片100%附著於汽缸表面，可避免啟動卡死與扭力不足的問題。

**OPTION 選配件**

**Handle Cover**



可加購握把護套增加其舒適感



WS-2050 (3/8") / 2051 (1/2")  
Twin Hammer



WS-2053  
Twin Hammer



WS-2055 (1/2") / 2056 (3/8")  
Two Hammer



WS-305JW1  
Jumbo Hammer

Model	Std. Bolt Cap.	Square Drive	Working Torque Range @ 2 sec.	Max. Torque @ 5 sec.	Free Speed	Length	Weight	Noise	Packing
型號	螺絲能力	前軸尺寸	工作扭力@2秒	最大扭力@5秒	無負載轉速	長度	重量	噪音值	包裝明細 (CTN)
	inch (mm)	inch	ft-lb (Nm)	ft-lb (Nm)	RPM	mm	kg	dB (A)	PC/CTN/N.W./G.W./CUFT
WS-2050	9/16" (14)	3/8"	20~300 (34~406)	400 (542)	12,000	145	1.6	95.4	10pcs/17kg/18kg/0.83'
WS-2051	9/16" (14)	1/2"	20~300 (34~406)	400 (542)	12,000	145	1.6	95.4	10pcs/17kg/18kg/0.83'
WS-2053	9/16" (14)	1/2"	20~300 (34~406)	400 (542)	12,000	140	1.6	95.4	10pcs/17kg/18kg/0.83'
WS-2055	9/16" (14)	1/2"	20~250 (34~338)	300 (406)	12,000	145	1.6	97.3	10pcs/17kg/18kg/0.83'
WS-2056	9/16" (14)	3/8"	20~180 (34~245)	250 (339)	12,000	145	1.6	97.3	10pcs/17kg/18kg/0.83'
WS-305JW1	7/16" (12)	1/2"	20~160 (34~217)	180 (245)	8,000	155	1.2	86.4	10pcs/13.4kg/14.4kg/0.83'

● Air Cons. / 工作耗氣量: 5.6 cfm (160 L/min)  
● Air Pressure / 空氣壓力: 90 psi (6.2bar)

● Air Inlet / 進氣口尺寸: 1/4" PT or NPT

● Min.HoseSize / 進氣管尺寸: 3/8" (9.5mm)

# Air Impact Wrench

## WS-202 & 203 Series 1/2" Impact Wrench

Blade with spring mounted to prevent dead-lock or power-less problem.

葉片彈簧裝置設計，使葉片100%附著於汽缸表面，可避免啟動卡死與扭力不足的問題。



WS-202 / 202L (2"Anvil)  
Twin Hammer



WS-203 / 203L (2"Anvil)  
Twin Hammer

### OPTION 選配件

#### Handle Cover



可加購握把護套  
增加其舒適感

專利2段式板機  
5段位扭力調節  
前方排氣

2 Step throttle trigger of patent  
5 Position Power regulator  
Front Exhaust

無段式板機  
5段位扭力調節  
握柄下方排氣

Tease Trigger  
5 Position Power regulator  
Handle Exhaust



WS-202K1 / 203K1



WS-202K2 / 203K2

#### Contents :

1. 1/2" Impact wrench / 氣動扳手 x 1
  2. 1/2" Impact sockets / 氣動套筒 x 3 (17, 19, 21mm)
  3. 1/2" x 5" extension bar / 氣動延長桿 x 1
  4. 5mm Hex key wrench / 六角扳手 x 1
  5. Mini oiler / 注油器 x 1
  6. Oil pot / 油壺 x 1
  7. Blow case / 吹氣盒 x 1
- Packing / 包裝明細 : 5sets/19kg/20kg/1.5'

#### Contents :

1. 1/2" Impact wrench / 氣動扳手 x 1
  2. 1/2" Deep Impact sockets / 氣動長套筒 x 3 (17, 19, 21mm)
  3. 5mm Hex key wrench / 六角扳手 x 1
  4. Mini oiler / 注油器 x 1
  5. Oil pot / 油壺 x 1
  6. Blow case / 吹氣盒 x 1
- Packing / 包裝明細 : 5sets/21kg/22kg/1.5'

Model	Std. Bolt Cap.	Square Drive	Working Torque Range @ 2 sec.	Max. Torque @ 5 sec.	Free Speed	Length	Weight	Noise	Packing
型號	螺絲能力	前軸尺寸	工作扭力@2秒	最大扭力@5秒	無負載轉速	長度	重量	噪音值	包裝明細 (CTN)
	inch (mm)	inch	ft-lb (Nm)	ft-lb (Nm)	RPM	mm	kg	dB (A)	PCS/N.W./G.W./CUFT
WS-202	9/16" (14)	1/2"	25~400 (34~540)	550 (746)	8,000	185	2.6	100.2	8pcs/22.5kg/23.5kg/1.2'
WS-202L	9/16" (14)	1/2"	25~400 (34~540)	545 (739)	7,500	235	2.7	100.2	8pcs/24kg/25kg/1.4'
WS-203	9/16" (14)	1/2"	25~400 (34~540)	560 (759)	8,000	185	2.6	102.1	8pcs/22.5kg/23.5kg/1.2'
WS-203L	9/16" (14)	1/2"	25~400 (34~540)	555 (753)	7,500	235	2.7	102.1	8pcs/24kg/25kg/1.4'

- Air Cons. / 工作耗氣量 : 7.1 cfm (200 L/min)
- Air Pressure / 空氣壓力 : 90 psi (6.2bar)

- Air Inlet / 進氣口尺寸 : 1/4" PT or NPT

- Min.HoseSize / 進氣管尺寸: 3/8" (9.5mm)



# Air Impact Wrench

## WS-208 Series

### 1/2" & 3/4" Impact Wrench

Blade with spring mounted to prevent dead-lock or power-less problem.  
葉片彈簧裝置設計，使葉片100%附著於汽缸表面，可避免啟動卡死與扭力不足的問題。



WS-208 (1/2") / 2086 (3/4")  
Twin Hammer



WS-208D (1/2")  
Two Hammer

#### OPTION 選配件

##### Handle Cover



可加購握把護套  
增加其舒適感

6 Position Power regulator: 3 settings in forward,  
3 in reverse.  
Handle Exhaust  
6段式扭力調節，正、逆轉各3段  
握柄下方排氣

Two Hammer mechanism  
favorable for soft joint of work

雙錘塊結構，適合軟結合工作

Model 型號	Std. Bolt Cap. 螺絲能力	Square Drive 前軸尺寸	Working Torque Range @ 2 sec. 工作扭力@2秒	Max. Torque @ 5 sec. 最大扭力@5秒	Free Speed 無負載轉速	Length 長度	Weight 重量	Noise 噪音值	Packing 包裝明細 (CTN)
	inch (mm)	inch	ft-lb (Nm)	ft-lb (Nm)	RPM	mm	kg	dB (A)	PCS/N.W./G.W./CUFT
WS-208	5/8" (16)	1/2"	50~550 (68~745)	800 (1,085)	7,500	178	2.62	101.8	8pcs/23kg/24kg/1.2'
WS-2086	13/16" (20)	3/4"	50~800 (68~1,085)	1,100 (1,490)	7,500	178	2.68	101.8	8pcs/23.5kg/24.5kg/1.2'
WS-208D	5/8" (16)	1/2"	50~390 (68~529)	450 (540)	7,500	178	2.62	101.8	8pcs/23kg/24kg/1.2'

● Air Cons. / 工作耗氣量 : 7.7 cfm (220 L/min)

● Air Inlet / 進氣口尺寸 : 1/4" PT or NPT

● Min.HoseSize / 進氣管尺寸 : 3/8" (9.5mm)

● Air Pressure / 空氣壓力 : 90 psi (6.2bar)

## WS-206 Series

### 3/4" & 1" Impact Wrench

Blade with spring mounted to prevent dead-lock or power-less problem.  
葉片彈簧裝置設計，使葉片100%附著於汽缸表面，可避免啟動卡死與扭力不足的問題。



WS-2066 (3/4") / 2066L (6" Anvil)  
Twin Hammer



WS-2068 (1") / 2068L (6" Anvil)  
Twin Hammer

#### OPTION 選配件

##### Handle Cover



可加購握把護套  
增加其舒適感

無段式板機  
6段式扭力調節，正、逆轉各3段  
握柄下方排氣

Tease Trigger  
6 Position Power regulator: 3 settings in forward, 3 in reverse.  
Handle Exhaust

Model 型號	Std. Bolt Cap. 螺絲能力	Square Drive 前軸尺寸	Working Torque Range @ 2 sec. 工作扭力@2秒	Max. Torque @ 5 sec. 最大扭力@5秒	Free Speed 無負載轉速	Length 長度	Weight 重量	Noise 噪音值	Packing 包裝明細 (CTN)
	inch (mm)	inch	ft-lb (Nm)	ft-lb (Nm)	RPM	mm	kg	dB (A)	PCS/N.W./G.W./CUFT
WS-2066	1-1/8" (30)	3/4"	100~1,000 (135~1,500)	1,400 (1,898)	7,500	210	4.13	95.3	6pcs/27.2kg/28.2kg/1.2'
WS-2066L	1-1/8" (30)	3/4"	100~1,000 (135~1,500)	1,200 (1,627)	7,500	358.5	4.7	95.3	4pcs/20.3kg/21.3kg/1.5'
WS-2068	1-1/8" (30)	1"	100~1,000 (135~1,500)	1,500 (2,034)	7,500	213	4.23	95.3	6pcs/27.5kg/28.5kg/1.2'
WS-2068L	1-1/8" (30)	1"	100~1,000 (135~1,500)	1,300 (1,763)	7,500	366	5	95.3	4pcs/21.7kg/22.7kg/1.5'

● Air Cons. / 工作耗氣量 : 10.6 cfm (300 L/min)

● Air Inlet / 進氣口尺寸 : 3/8" PT or NPT

● Min.HoseSize / 進氣管尺寸 : 1/2" (12.7mm)

● Air Pressure / 空氣壓力 : 90 psi (6.2bar)

# Air Impact Wrench

## WS-216 Series 1" Impact Wrench



WS-216 (1")  
Twin Hammer

### OPTION 選配件

#### Straight Handle



直把手



Patented hammer assemblies with fully sealed oil, the designs can extend lifetime under full lubrication, so is a solution to poor lubrication which is disadvantage of Twin Hammer mechanism.

Tease Trigger.

6 Position Power regulator : 3 settings in forward, 3 in reverse.

Handle Exhaust.

Blade with spring mounted to prevent dead-lock or power-less problem.

專利鏈打組全密封含油式，充分潤滑可延長壽命，解決目前雙環結構潤滑不良的缺點。

無段式板機。

6段式扭力調節，正、逆轉各3段。

握柄下方排氣。

葉片彈簧裝置設計，使葉片100%附著於汽缸表面，可避免啟動卡死與扭力不足的問題。

Model	Std. Bolt Cap.	Square Drive	Working Torque Range @2 Sec	Max. Torque @5 Sec	Free Speed	Length	Weight	Air Inlet	Air Cons.
型號	螺絲能力	前軸尺寸	工作扭力@2秒	最大扭力@5秒	無負載轉速	長度	重量	進氣口尺寸	空氣耗氣量
	inch (mm)	inch	ft-lb (Nm)	ft-lb (Nm)	RPM	mm	kg	PT or NPT	cfm (l/min)
WS-216	1-3/4"(45)	1"	500~2,000 (678~2,711)	2,200 (2,983)	6,000	249	7.57	1/2"	13.4 (380)

• Min.HoseSize / 進氣管尺寸: 3/4" (19mm)

• Air Pressure / 空氣壓力: 90 psi (6.2bar)

## WS-215 Series 1" Impact Wrench

### 專利

Patented hammer assemblies with fully sealed oil, the designs can extend lifetime under full lubrication, so is a solution to poor lubrication which is disadvantage of Twin Hammer mechanism.

2 Step throttle trigger of patent for improving the convenient operation.

2 type of trigger mechanism for option: outside type, inside type.

2 angle of Inlet Fitting: 60 and straight for option.

4 Position Power regulator, separate switch between Forward and Reverse.

Blade with spring mounted to prevent dead-lock or power-less problem.

專利鏈打組全密封含油式，充分潤滑可延長壽命，解決目前雙環結構潤滑不良的缺點。

專利兩段式板機，可以提升操作便利性。

內板機和外板機供客戶選擇。

60度、直型，兩種進氣角度供客戶選擇。

4段式扭力調節，獨立正逆轉開關。

葉片彈簧裝置設計，使葉片100%附著於汽缸表面，可避免啟動卡死與扭力不足的問題。



WS-215T-2 (1")  
Twin Hammer



WS-215T-8 (1")  
Twin Hammer



Model	Std. Bolt Cap.	Square Drive	Working Torque Range @2 Sec	Max. Torque @5 Sec	Free Speed	Length	Weight	Air Inlet	Air Cons.
型號	螺絲能力	前軸尺寸	工作扭力@2秒	最大扭力@5秒	無負載轉速	長度	重量	進氣口尺寸	空氣耗氣量
	inch (mm)	inch	ft-lb (Nm)	ft-lb (Nm)	RPM	mm	kg	PT or NPT	cfm (l/min)
WS-215T-2	1-3/4" (45)	1"	500~2,000 (678~2,711)	2,200 (2,983)	6,000	555	8.3	1/2"	13.4 (380)
WS-215T-8	1-3/4" (45)	1"	500~2,000 (678~2,711)	2,200 (2,983)	6,000	555	9.48	1/2"	13.4 (380)

• Min.HoseSize / 進氣管尺寸: 3/4" (19mm)

• Air Pressure / 空氣壓力: 90 psi (6.2bar)



# Air Impact Wrench

## WS-212 Series

### 1" Impact Wrench

#### Anvil & Hammer Assemblies

Heavy duty anvil and Hammer assemblies made from Nickel Chromium Molybdenum Alloy steel through special treatment with long lifespan.

#### 傳動軸 鎚打組

由鎳鉻鋁合金鋼材料製造成的傳動軸和鎚打組經特殊熱處理之後更能延長零件壽命。

#### Trigger

2 types of trigger mechanism for option : outside type or inside type.

#### 板機

內板機和外板機兩種機種供客戶選擇。



Outside Trigger type  
外板機



Inside Trigger type  
內板機

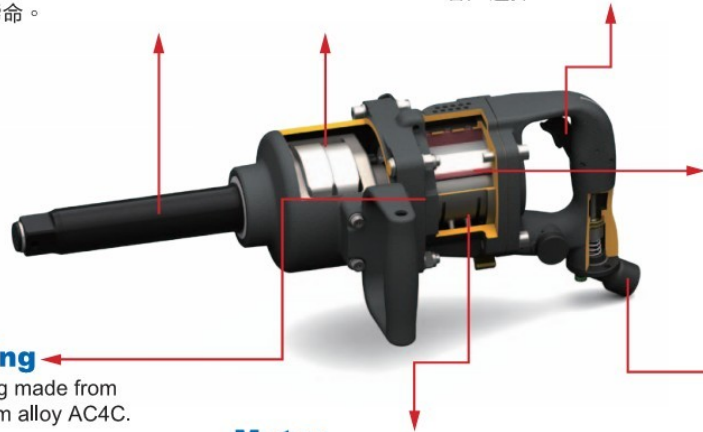

#### Blade 葉片

Blade with spring mounted to prevent dead-lock or power-less problem.

葉片彈簧裝置設計，使葉片100%附著於汽缸表面，可避免啟動卡死與扭力不足的問題。

#### Motor Housing

Solid, sturdy housing made from high grade Aluminum alloy AC4C.

#### 馬達外殼

由高級鋁合金料 AC4C 製造成緊實堅固的馬達外殼。

#### Motor

Solid, compact, low air consumption design of Motor.

#### 馬達

緊實、小巧、低耗氣量的馬達設計。

#### Inlet Bushing

3 angles of inlet fitting : 60, 90, straight for option.



#### 進氣口

60度、90度、直型，三種進氣角度供客戶選擇。



WS-212T-2 / 212P-2  
Twin Hammer/Pin Less



WS-212T-8 / 212P-8  
Twin Hammer/Pin Less

Model 型號	Std. Bolt Cap. 螺絲能力	Square Drive 前軸尺寸	Working Torque Range @ 2 sec. 工作扭力 @2秒	Max. Torque @ 5 sec. 最大扭力 @5秒	Length 長度	Weight 重量	Noise 噪音值	Packing 包裝明細 (CTN)
	inch (mm)	inch	ft-lb (Nm)	ft-lb (Nm)	mm	kg	dB (A)	PCS/N.W./G.W./CUFT
WS-212T-2	1-3/4" (45)	1"	700-2,400 (952-3,270)	2,600 (3,520)	370	10.5	94.5	1pc/10.7kg/11.7kg/0.65' 2pcs/21.9kg/22.9kg/1.3'
WS-212T-6	1-3/4" (45)	1"	700-2,400 (952-3,270)	2,600 (3,520)	522	11.5	94.5	1pc/12.4kg/13.4kg/1'
WS-212T-8	1-3/4" (45)	1"	700-2,400 (952-3,270)	2,600 (3,520)	570	11.9	94.5	1pc/12.9kg/13.9kg/1'
WS-212P-2	1-3/4" (45)	1"	700-2,400 (952-3,270)	2,800 (3,796)	370	11	94.5	1pc/11.4kg/12.4kg/0.65' 2pcs/23.3kg/24.3kg/1.3'
WS-212P-6	1-3/4" (45)	1"	700-2,400 (952-3,270)	2,800 (3,796)	522	12	94.5	1pc/13.1kg/14.1kg/1'
WS-212P-8	1-3/4" (45)	1"	700-2,400 (952-3,270)	2,800 (3,796)	570	12.5	94.5	1pc/13.6kg/14.6kg/1'

- Free Speed / 無負載轉速 : 4,800rpm
- Min. Hose Size / 進氣管尺寸 : 3/4" (19mm)

- Air Cons. / 空氣耗氣量 : 16 cfm (450 L/min)
- Air Pressure / 空氣壓力 : 90 psi (6.2bar)

- Air Inlet / 進氣口尺寸 : 1/2" PT or NPT



# Air Impact Wrench

## WS-210 Series 3/4" & 1" Impact Wrench

2 Step throttle trigger of patent for improving the convenient operation.  
Blade with spring mounted to prevent dead-lock or power-less problem.

專利兩段式板機，可以提升操作便利性。  
葉片彈簧裝置設計，使葉片100%附著於汽缸表面，可避免啟動卡死與扭力不足的問題。



WS-2106 (3/4") / 2108 (1")  
Twin Hammer



WS-2106L (3/4") / 2108L (1")  
Twin Hammer (6"Anvll)

### OPTION 選配件

**Straight Handle**  
直把手



Model	Std. Bolt Cap.	Square Drive	Working Torque Range @ 2 sec.	Max. Torque @ 5 sec.	Length	Weight	Noise	Packing
型號	螺絲能力	前軸尺寸	工作扭力@2秒	最大扭力@5秒	長度	重量	噪音值	包裝明細 (CTN)
	inch (mm)	inch	ft-lb (Nm)	ft-lb (Nm)	mm	kg	dB (A)	PCS/N.W./G.W./CUFT
WS-2106	1-1/8" (30)	3/4"	100~1,000 (135-1,500)	1,400 (1,898)	286.5	4.5	99.8	4pcs/18.5kg/19.5kg/0.85'
WS-2106L	1-1/8" (30)	3/4"	100~1,000 (135-1,500)	1,200 (1,627)	434	5	99.8	4pcs/22.5kg/23.5kg/1.2'
WS-2108	1-1/8" (30)	1"	100~1,000 (135-1,500)	1,500 (2,034)	288.6	4.6	99.8	4pcs/18.6kg/19.6kg/0.85'
WS-2108L	1-1/8" (30)	1"	100~1,000 (135-1,500)	1,300 (1,763)	441.6	5.4	99.8	4pcs/22.9kg/23.9kg/1.2'

- Free Speed / 無負載轉速 : 7,500rpm
- Air Inlet / 進氣口尺寸 : 3/8" PT or NPT

- Air Cons. / 工作耗氣量 : 10.6 cfm (300 L/min)
- Air Pressure / 空氣壓力 : 90 psi (6.2bar)

- Min.HoseSize / 進氣管尺寸 : 1/2"(12.7mm)

## WX-255 1-1/2" Impact Wrench

5 Position Power regulator : 4 settings in forward, 1 in reverse.

5段式扭力調節，正轉4段、逆轉1段。



WX-255  
Twin Hammer

Model	Std. Bolt Cap.	Square Drive	Working Torque Range @ 2 sec.	Max. Torque @ 5 sec.	Length	Weight	Noise	Packing
型號	螺絲能力	前軸尺寸	工作扭力@2秒	最大扭力@5秒	長度	重量	噪音值	包裝明細 (CTN)
	inch (mm)	inch	ft-lb (Nm)	ft-lb (Nm)	mm	kg	dB (A)	PCS/N.W./G.W./CUFT
WX-255	1-3/4" (50)	1-1/2"	500~1,617 (678~2,192)	3,000 (4,068)	450	17.1	101	1pc/19.7kg/22.2kg/1.5'

- Free Speed / 無負載轉速 : 3,000rpm
- Min. HoseSize / 進氣管尺寸 : 3/4" (19mm)

- Air Cons. / 空氣耗氣量 : 16cfm (453 L/min)
- Air Pressure / 空氣壓力 : 90 psi (6.2bar)

- Air Inlet / 進氣口尺寸 : 1/2" PT or NPT

# Air Ratchet Wrench

Full Cage Gear Design 齒輪設計。  
Long Service Life 高使用壽命。



WX-2802



WX-2803



WX-2804 / 2814



WX-2815  
Quick Change



WX-2824

Model 型號	Square Size 前軸尺寸	Std. Bolt Cap. 螺絲能力	Free Speed 無負載轉速	Torque 扭力	Air Cons. 工作耗氣量	Length 長度	Weight 重量	Min. Hose Size 進氣管尺寸	Noise 噪音值	Packing 包裝明細 (CTN)
	inch	mm	RPM	Nm	cfm (l/min)	mm	kg	inch (mm)	dB (A)	PCS/N.W./G.W./CUFT
WX-2802	1/4"	6	260	35	5.34 (150)	130	0.45	1/4" (6.35)	99	20pcs/9kg/10kg/0.4'
WX-2803	3/8"	6	260	35	5.69 (160)	130	0.45	1/4" (6.35)	99.9	20pcs/9kg/10kg/0.4'
WX-2804	3/8"	10	160	81	9.5 (240)	254	1.2	3/8" (9.5)	91.4	20pcs/24kg/26kg/1.2'
WX-2814	1/2"	10	160	80	9.5 (240)	254	1.2	3/8" (9.5)	91.4	20pcs/24kg/26kg/1.2'
WX-2824	1/2"	10	150	75	9.5 (240)	254	1.3	3/8" (9.5)	91.4	20pcs/24kg/26kg/1.2'
WX-2815	1/2"	10	160	80	9.5 (240)	254	1.2	3/8" (9.5)	91.6	20pcs/24kg/26kg/1.2'

• Air Pressure / 空氣壓力 : 90 psi (6.2bar)

• Air Inlet / 進氣口尺寸 : 1/4" PT or NPT



WX-2805



WX-2806

Model 型號	Square Size 前軸尺寸	Std. Bolt Cap. 螺絲能力	Free Speed 無負載轉速	Torque 扭力	Air Cons. 工作耗氣量	Length 長度	Weight 重量	Min. Hose Size 進氣管尺寸	Noise 噪音值	Packing 包裝明細 (CTN)
	inch	mm	RPM	Nm	cfm (l/min)	mm	kg	inch (mm)	dB (A)	PCS/N.W./G.W./CUFT
WX-2805	1/2"	10	400	68	7 (198)	295	1.29	3/8" (9.5)	94.5	10pcs/13kg/15kg/0.9'
WX-2806	1/2"	10	180	176	4.5 (127)	317	1.54	3/8" (9.5)	90	10pcs/16.6kg/17.6kg/1.03'

• Air Pressure / 空氣壓力 : 90 psi (6.2bar)

• Air Inlet / 進氣口尺寸 : 1/4" PT or NPT



WX-2808 / 2809

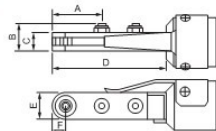

Model 型號	A	B	C	D	E	F
	mm	mm	mm	mm	mm	mm
WX-2808	38.2	20	13.2	88.2	20	10.2
WX-2809	44.4	26	18	109	25.2	12.2

Model 型號	Hex Size 六角尺寸	Working Torque 工作扭力	Max. Torque 最大扭力	Free Speed 無負載轉速	Length 長度	Weight 重量	Air Cons. 工作耗氣量	Noise 噪音值	Packing 包裝明細 (CTN)	
	mm	inch	Nm	Nm	RPM	mm	kg	cfm (l/min)	dB (A)	PCS/N.W./G.W./CUFT
WX-2808	6,7,8,10,11,12	1/4", 3/8"	10	10	180	300	1.3	4.5 (127)	86	10pcs/13.3/16.4/1.4
WX-2809	10,11,12,13,14	1/2", 9/16"	15	25	250	340	1.8	7.5 (212)	87	10pcs/18.7/21.6/1.4

• Air Pressure / 空氣壓力 : 90 psi (6.2bar)

• Air Inlet / 進氣口尺寸 : 1/4" PT or NPT

• Rear Exhaust / 後排氣

• Standard / 出廠標準尺寸 : 10mm

# Composite Impact Wrench

Twin Hammer mechanism to perform best impact torque output, and special Hardened-Treatment to maintain best durability.

雙環式打擊結構，扭力輸出頻率穩定，特殊強化處理壽命高。

Special Hardened-Treated Cylinder

Front plate and Rear plate to generate best durability.

汽缸材質為球墨鑄鐵，耐磨性佳。  
前後蓋為鋁合金材質，表面特殊處理耐磨性佳。

Titanium clutch case to re-enforce the strength.  
鈦合金前護蓋，增強其耐用度與安全性。



Blade with spring mounted to prevent dead-lock or power-less problem.  
葉片彈簧裝置設計，使葉片100%附著於汽缸表面，可避免啟動卡死與扭力不足的問題。

360 degree swivel air inlet to prevent air hose twisted.

進氣接頭可360度旋轉，可避免氣管打結。

3 settings in forward, 1 in reverse.  
4段式扭力調節，正3段、逆轉1段。

Composite handle to provide power-to-weight ratio, and prevent uncomfortable usage during temperature change.

塑鋼本體重量輕，本體握把設計符合人體工學。



WX-21064  
3/8" Composite Impact Wrench



WX-21079  
1/2" Mini Composite Impact Wrench



WX-21015  
1/2" Composite Impact Wrench



WX-21035  
3/4" Mini Composite Impact Wrench



WX-21077  
3/4" Composite Impact Wrench



WX-21078  
1" Mini Composite Impact Wrench

Model 型號	Square Drive 前軸尺寸	Std. Bolt Cap. 螺絲能力	Working Torque 工作扭力	Free Speed 無負載轉速	Air Cons. @ Load 負載中耗氣量	Length 長度	Weight 重量	Air Inlet 進氣口尺寸	Noise 噪音值	Packing 包裝明細 (CTN)
	inch	inch (mm)	ft-lb (Nm)	RPM	cfm (l/min)	mm	kg	PT or NPT	dB (A)	PCS/N.W./G.W./CUFT
WX-21064	3/8"	9/16" (14)	230 (312)	8,000	8.1 (230)	160	1.3	1/4"	89.5	10pcs/14.3kg/15.3kg/0.9'
WX-21079	1/2"	5/8" (16)	325 (440)	11,000	8.1 (230)	160	1.3	1/4"	85.2	10pcs/14.7kg/15.7kg/0.9'
WX-21015	1/2"	5/8" (16)	523 (709)	8,500	8.8 (250)	190	2.1	1/4"	90.9	10pcs/23.5kg/24.5kg/1.6'
WX-21035	3/4"	5/8" (16)	600 (814)	8,500	8.8 (250)	195	2.3	1/4"	90.9	10pcs/24kg/25kg/1.6'
WX-21077	3/4"	1-1/8" (30)	1,320 (1,800)	5,500	12.7 (360)	220	3.6	3/8"	96.9	6pcs/23.3kg/24.3kg/1.3'
WX-21078	1"	1-1/8" (30)	1,320 (1,800)	5,500	12.7 (360)	230	3.8	3/8"	96.9	6pcs/23.9kg/24.9kg/1.3'

• Air Pressure / 空氣壓力 : 90 psi (6.2bar)



# Air Screwdriver



WS-301 / 301J / 301P  
Two Hammer / Jumbo Hammer / Pin Less



WS-302  
Two Hammer



WS-303  
Two Hammer



WS-305 / 305J / 305P  
Two Hammer / Jumbo Hammer / Pin Less

## WS-301 Series / WS-301J Series

- 4 step torque regulator.
- The pneumatic motor with high effect designed, the high torque output of low consumption.
- 4段式扭力調節。
- 高效能氣動馬達設計，低耗氣、高扭力輸出。

## WS-302 Series

- 2 steps throttle trigger of patent, it is accurate and convenient to control.
- Ergonomic designed for long time work without weary.
- Two hammer mechanism, vibration is small, suitable for Phillips screw works.
- 專利2段式板機，操控精確又便利。
- 人體工學設計，長時間作業不易疲勞。
- 雙鎚塊結構，振動小，適合十字螺絲作業。

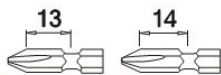

Select the proper type of bit according to the specification of your screwdriver

Model	Std. Bolt Cap.	Hex. Drive	Torque @0.5 Sec	Torque @2 Sec	Free Speed	Air Cons. @Load	Length	Weight	Noise	Packing
型號	螺絲能力	前軸尺寸	0.5秒扭力	2秒扭力	無負載轉速	負載中耗氣量	長度	重量	噪音值	包裝明細 (CTN)
	mm	inch	Nm	Nm	RPM	cfm (l/min)	mm	kg	dB (A)	PCS/N.W./G.W./CUFT
WS-301	6~8	1/4"	58	60	8,000	4.6 (130)	217	1.3	92.3	12pcs/17.5kg/18kg/0.9'
WS-301J	6~8	1/4"	57	59	8,000	4.6 (130)	217	1.3	92.3	12pcs/17.5kg/18kg/0.9'
WS-301P	6~8	1/4"	63	68	8,000	4.6 (130)	217	1.36	92.3	12pcs/18.3kg/19kg/0.9'
WS-302	6~8	1/4"	45	55	8,000	5.6 (160)	198	1	91.1	20pcs/22.5kg/23.5kg/1.4'
WS-303	6~8	1/4"	50	57	8,500	5.8 (165)	172	1.05	88.7	10pcs/12kg/13kg/0.9'
WS-305	6~8	1/4"	58	60	8,000	4.6 (130)	155	1.2	81.4	10pcs/13.4kg/14.4kg/0.83'
WS-305J	6~8	1/4"	57	59	8,000	4.6 (130)	155	1.2	81.4	10pcs/13.4kg/14.4kg/0.83'
WS-305P	6~8	1/4"	63	69	8,000	4.6 (130)	155	1.26	81.4	10pcs/14.2kg/15.2kg/0.83'

• Air Pressure / 空氣壓力 : 90 psi (6.2bar)

• Min. Hose Size / 進氣管尺寸 : 1/4" (6.35mm)

• Air Inlet / 進氣口尺寸 : 1/4" PT or NPT



### Two Hammer

Two Hammer mechanism, vibration is small, suitable for Phillips screw works and soft joint works.  
雙鎚塊結構，振動小，適合十字螺絲起子作業、軟結合。



### Jumbo Hammer

Jumbo Hammer mechanism, high torque, good durability, and low costs to maintain. (Hard joint of works)  
單環鎚打結構，高扭力，耐久性佳，維護成本低，適用於硬結合。(不適合十字螺絲)

# Mini Impact Wrench



## WS-303 Series

- 2 steps throttle trigger of patent, it is accurate and convenient to control.
- Ergonomic designed for long time work without weary.
- Two hammer mechanism, vibration is small, suitable for Phillips screw works.
- Swivel handle exhaust.
- 專利2段式板機，操控精確又便利。
- 人體工學設計，長時間作業不易疲勞。
- 雙錘塊結構，振動小，適合十字螺絲作業。
- 排氣口可360度旋轉。

## WS-305 Series

- 2 steps throttle trigger for precise control.
- Rigid hammer housing made of hot forged steel for excellent durability.
- Swivel handle exhaust.
- Comfortable contoured handle.
- 兩段式板機，可精確控制。
- 錘打組為熱鍛加工，具有特優的耐久性。
- 可旋轉式下排氣裝置。
- 具有舒適操控的把手。

Model 型號	Std. Bolt Cap. 螺絲能力	Sq. Drive Size 前軸尺寸	Torque @0.5 Sec 0.5秒扭力	Torque @2 Sec 2秒扭力	Free Speed 無負載轉速	Air Cons. @Load 負載中耗氣量	Length 長度	Weight 重量	Noise 噪音值	Packing 包裝明細 (CTN)
	mm	inch	Nm	Nm	RPM	cfm (l/min)	mm	kg	dB (A)	PCS/N.W./G.W./CUFT
WS-301W	6~8	3/8"	65	80	8,000	2.5 (70)	210	1.3	92.3	12pcs/17.5kg/18kg/0.9'
WS-301JW	8~10	3/8"	82	94	8,000	4.6 (130)	210	1.3	92.3	12pcs/17.5kg/18kg/0.9'
WS-301PW	8~10	3/8"	78	89	8,000	4.6 (130)	210	1.36	92.3	12pcs/18.3kg/19kg/0.9'
WS-302W	6~8	3/8"	55	62	8,000	5.6 (160)	190	1	91.1	20pcs/22.5kg/23.5kg/1.4'
WS-303W	6~8	3/8"	58	65	8,500	5.8 (165)	164	1.05	88.7	10pcs/12kg/13kg/0.9'
WS-305W	6~8	3/8"	80	90	8,000	4.6 (130)	155	1.2	81.4	10pcs/13.4kg/14.4kg/0.83'
WS-305JW	6~8	3/8"	82	94	8,000	4.6 (130)	155	1.2	81.4	10pcs/13.4kg/14.4kg/0.83'
WS-305PW	6~8	3/8"	79	89	8,000	4.6 (130)	155	1.26	81.4	10pcs/14.2kg/15.2kg/0.83'

• Air Pressure / 空氣壓力 : 90 psi (6.2bar)

• Min. Hose Size / 進氣管尺寸 : 1/4" (6.35mm)

• Air Inlet / 進氣口尺寸 : 1/4" PT or NPT



## Pin Less

Pinless mechanism, strong power on single hit with long durability. Available for both soft and hard joint of works. 無銷式結構，單次打擊能力強，耐久性佳，軟、硬結合同時共用。

# Air Screwdriver

## Corner Driver [90°]

2 Step throttle trigger of patent  
90 angle head allows flexibility in tight spots.

專利兩段式板機。  
前端90度設計，使不易維修處更彈性。



WS-304  
1/4" Corner Screwdriver Two Hammer



WS-304W  
3/8" Corner Impact Driver Two Hammer

Model	Std. Bolt Cap.	Drive Size	Torque @0.5 Sec	Torque @2 Sec	Free Speed	Air Cons. @Load	Length	Weight	Noise	Packing
型號	螺絲能力	前軸尺寸	0.5秒扭力	2秒扭力	無負載轉速	負載中耗氣量	長度	重量	噪音值	包裝明細 (CTN)
	mm	inch	Nm	Nm	RPM	cfm (l/min)	mm	kg	dB (A)	PCS/N.W./G.W./CUFT
WS-304	6~8	1/4" Hex.	37	43	8,000	5.6 (160)	217	1.3	86.4	12pcs/17.5kg/18.3kg/0.9'
WS-304W	6~8	3/8" Sq.	52	57	8,000	5.6 (160)	217	1.3	86.4	12pcs/17.5kg/18.3kg/0.9'

• Air Pressure / 空氣壓力 : 90 psi (6.2bar)

• Min. Hose Size / 進氣管尺寸 : 1/4" (6.35mm)

• Air Inlet / 進氣口尺寸 : 1/4" PT or NPT

# Air Screwdriver

## Super Ultra Series

6 Position Power regulator : 3 settings in forward, 3 in reverse.  
正、逆轉各3段位扭力調節。



WS-2052  
Twin Hammer



WS-2057  
Two Hammer-for soft joint of work

Model	Std. Bolt Cap.	Hex. Drive	Torque @0.5Sec	Torque @2 Sec	Free Speed	Air Cons. @Load	Length	Weight	Noise	Packing
型號	螺絲能力	前軸尺寸	0.5秒扭力	2秒扭力	無負載轉速	負載中耗氣量	長度	重量	噪音值	包裝明細 (CTN)
	mm	inch	Nm	Nm	RPM	cfm (l/min)	mm	kg	dB (A)	PCS/N.W./G.W./CUFT
WS-2052	12	1/4"	190	200	12,000	5.6 (160)	145	1.6	95.4	10pcs/17kg/18kg/0.83'
WS-2057	10	1/4"	100	110	12,000	5.6 (160)	145	1.6	97.3	10pcs/17kg/18kg/0.83'

• Air Pressure / 空氣壓力 : 90 psi (6.2bar)

• Min. Hose Size / 進氣管尺寸 : 3/8" (9.5mm)

• Air Inlet / 進氣口尺寸 : 1/4" PT or NPT



# Air Screwdriver

## Economy 經濟型



WX-3208  
Two Hammer



WX-3218  
Twin Hammer

Model 型號	Std. Bolt 螺絲能力	Hex. Drive 前軸尺寸	Max. Torque 最大扭力	Free Speed 無負載轉速	Air Cons. @Load 負載中耗氣量	Length 長度	Weight 重量	Noise 噪音值	Packing 包裝明細 (CTN)
	mm	inch	Nm	RPM	cfm (l/min)	mm	kg	dB (A)	PCS/N.W./G.W./CUFT
WX-3208	8	1/4"	55	9,000	7 (198)	155	1.18	86.5	10pcs/13.3kg/14.3kg/0.9'
WX-3218	8	1/4"	74	9,000	12 (340)	155	1.18	84.7	10pcs/12kg/14kg/0.9'

• Air Pressure / 空氣壓力 : 90 psi (6.2bar)

• Min. Hose Size / 進氣管尺寸 : 1/4" (6.35mm)

• Air Inlet / 進氣口尺寸 : 1/4" PT or NPT



WX-3155S  
Two Hammer



WX-3155A  
Two Hammer



WX-325HP  
Two Hammer



WX-318H  
Two Hammer



WX-328HL  
Two Hammer



WX-316LS  
Two Hammer

Model 型號	Std. Bolt 螺絲能力	Hex. Drive 前軸尺寸	Max. Torque 扭力	Free Speed 無負載轉速	Air Cons. @Load 負載中耗氣量	Length 長度	Weight 重量	Noise 噪音值	Packing 包裝明細 (CTN)
	mm	inch	Nm	RPM	cfm (l/min)	mm	kg	dB (A)	PCS/N.W./G.W./CUFT
WX-3155S	M3~M6	1/4"	47	14,000	6 (170)	187	0.78	95.3	20pcs/17.7kg/18.7kg/1'
WX-3155A	M4~M5	1/4"	25	12,000	6 (170)	193	1.1	96.6	20pcs/23.9kg/24.9kg/1'
WX-325HP	M4~M5	1/4"	46	16,000	8.8 (250)	140	0.87	95.5	10pcs/10.6kg/11.6kg/0.9'
WX-318H	M6~M8	1/4"	48	10,000	6.7 (190)	208	0.98	96.5	20pcs/24.9kg/25.9kg/1'
WX-328HL	M6~M8	1/4"	26	9,800	6.3 (180)	275	1.36	96.1	20pcs/29.3kg/30.3kg/1'
WX-316LS	M6~M8	1/4"	49	10,000	7.7 (220)	180	1.15	94.8	10pcs/15.4kg/16.4kg/1.5'

• Air Pressure / 空氣壓力 : 90 psi (6.2bar)

• Min. Hose Size / 進氣管尺寸 : 1/4" (6.35mm)

• Air Inlet / 進氣口尺寸 : 1/4" PT or NPT

# Shut Off Screwdriver



WX-3T-PB Series



WX-3T-LB Series



WX-3T-PBE Series

Push Start Shut off - Straight type / 直型下壓式全自動氣動起子

Model	Free Speed	Weight	Length	Dia	Air Hose Size	Torque Range	Air cons.	Fastening Capacity		Noise	Packing
型號	轉速	重量	長度	把手外徑	進氣管尺寸	扭力範圍	工作耗氣量	機械螺絲	自攻螺絲	噪音值	包裝明細 (CTN)
	RPM	g	mm	mm	mm	Kgf-cm	m <sup>3</sup> /min	基準T	2.0T	dB (A)	PCS/N.W./G.W./CUFT
WX-3T10PB	1,000	480	180	31	5.0	0.5-2	0.28	M1.0-M2.2	M1.1-M1.7	67	10pcs/6kg/7kg/0.58'
WX-3T20PB	1,000	480	180	31	5.0	1-8	0.28	M1.7-M3.3	M1.3-M2.7	67	10pcs/6kg/7kg/0.58'
WX-3T30PB	1,800	480	180	31	5.0	3-17	0.28	M2.2-M4.2	M1.7-M3.2	67	10pcs/6kg/7kg/0.58'
WX-3T35PB	2,200	480	180	31	5.0	3-20	0.28	M2.2-M4.5	M1.7-M3.5	67	10pcs/6kg/7kg/0.58'
WX-3T40PB	1,000	480	180	31	5.0	5-30	0.28	M2.8-M5.0	M2.2-M4.0	67	10pcs/6kg/7kg/0.58'
WX-3T45PB	8,00	480	180	31	8.0	8-40	0.28	M3.3-M5.7	M2.7-M4.4	67	10pcs/6kg/7kg/0.58'
WX-3T48PB	1,800	790	215	39	8.0	5-45	0.55	M2.8-M5.8	M2.2-M4.7	72	10pcs/10kg/11kg/0.75'
WX-3T50PB	1,400	790	215	39	8.0	7-50	0.55	M2.9-M6.0	M2.6-M4.9	72	10pcs/10kg/11kg/0.75'
WX-3T55PB	1,000	790	215	39	8.0	7-65	0.55	M2.9-M6.4	M2.6-M5.4	72	10pcs/10kg/11kg/0.75'
WX-3T60PB	550	790	215	39	8.0	15-95	0.55	M4.1-M7.0	M3.1-M6.0	72	10pcs/10kg/11kg/0.75'
WX-3T65PB	300	810	215	39	8.0	30-180	0.55	M5.0-M9.3	M4.0-M7.2	72	10pcs/10kg/11kg/0.75'
WX-3T68PB	250	810	215	39	8.0	50-280	0.55	M6.0-M11.0	M4.9-M8.7	72	10pcs/10kg/11kg/0.75'

Lever Start Shut off - Straight type / 直型壓板式全自動氣動起子

Model	Free Speed	Weight	Length	Dia	Air Hose Size	Torque Range	Air cons.	Fastening Capacity		Noise	Packing
型號	轉速	重量	長度	把手外徑	進氣管尺寸	扭力範圍	空氣耗氣量	機械螺絲	自攻螺絲	噪音值	包裝明細 (CTN)
	RPM	g	mm	mm	mm	Kgf-cm	m <sup>3</sup> /min	基準T	2.0T	dB (A)	PCS/N.W./G.W./CUFT
WX-3T10LB	1,000	520	205	29	5.0	0.5-2	0.2	M1.0-M2.2	M1.1-M1.7	67	10pcs/7kg/8kg/0.58'
WX-3T20LB	1,000	520	205	29	5.0	1-8	0.2	M1.7-M3.3	M1.3-M2.7	67	10pcs/7kg/8kg/0.58'
WX-3T30LB	1,800	520	205	29	5.0	3-17	0.28	M2.2-M4.2	M1.7-M3.2	67	10pcs/7kg/8kg/0.58'
WX-3T35LB	2,200	520	205	29	5.0	3-20	0.28	M2.2-M4.5	M1.7-M3.5	67	10pcs/7kg/8kg/0.58'
WX-3T40LB	1,000	520	205	29	5.0	5-30	0.28	M2.8-M5.0	M2.2-M4.0	67	10pcs/7kg/8kg/0.58'
WX-3T45LB	800	520	205	29	8.0	8-40	0.3	M3.3-M5.7	M2.7-M4.4	69	10pcs/7kg/8kg/0.58'
WX-3T48LB	1,800	820	240	37	8.0	5-45	0.55	M2.8-M5.8	M2.2-M4.7	69	10pcs/11kg/12kg/0.75'
WX-3T50LB	1,400	820	240	37	8.0	7-50	0.55	M2.9-M6.0	M2.6-M4.9	69	10pcs/11kg/12kg/0.75'
WX-3T55LB	1,000	820	240	37	8.0	7-65	0.55	M2.9-M6.4	M2.6-M5.4	69	10pcs/11kg/12kg/0.75'
WX-3T60LB	550	820	240	37	8.0	15-95	0.55	M4.1-M7.0	M3.1-M6.0	69	10pcs/11kg/12kg/0.75'
WX-3T65LB	300	840	240	37	8.0	30-180	0.55	M5.0-M9.3	M4.0-M7.2	69	10pcs/11kg/12kg/0.75'
WX-3T68LB	250	840	240	37	8.0	50-280	0.55	M6.0-M11.0	M4.9-M8.7	69	10pcs/11kg/12kg/0.75'

Push Start Shut off - Straight type (for environment protect) / 直型下壓式全自動氣動起子 (環保消音裝置)

Model	Free Speed	Weight	Length	Dia	Air Hose Size	Torque Range	Air cons.	Fastening Capacity		Noise	Packing
型號	轉速	重量	長度	把手外徑	進氣管尺寸	扭力範圍	空氣耗氣量	機械螺絲	自攻螺絲	噪音值	包裝明細 (CTN)
	RPM	g	mm	mm	mm	Kgf-cm	m <sup>3</sup> /min	基準T	2.0T	dB (A)	PCS/N.W./G.W./CUFT
WX-3T10PBE	1,000	480	180	29	5.0	0.5-2	0.28	M1.0-M2.2	M1.1-M1.7	67	10pcs/6kg/7kg/0.58'
WX-3T20PBE	1,000	480	180	29	5.0	1-8	0.28	M1.7-M3.3	M1.3-M2.7	67	10pcs/6kg/7kg/0.58'
WX-3T30PBE	1,800	480	180	29	5.0	3-17	0.28	M2.2-M4.2	M1.7-M3.2	67	10pcs/6kg/7kg/0.58'
WX-3T35PBE	2,200	480	180	29	5.0	3-20	0.28	M2.2-M4.5	M1.7-M3.5	67	10pcs/6kg/7kg/0.58'
WX-3T40PBE	1,000	480	180	29	5.0	5-30	0.28	M2.8-M5.0	M2.2-M4.0	67	10pcs/6kg/7kg/0.58'
WX-3T45PBE	800	480	180	29	8.0	8-40	0.28	M3.3-M5.7	M2.7-M4.4	67	10pcs/6kg/7kg/0.58'
WX-3T48PBE	1,800	790	215	37	8.0	5-45	0.55	M2.8-M5.8	M2.2-M4.7	72	10pcs/10kg/11kg/0.75'
WX-3T50PBE	1,400	790	215	37	8.0	7-50	0.55	M2.9-M6.0	M2.6-M4.9	72	10pcs/10kg/11kg/0.75'
WX-3T55PBE	1,000	790	215	37	8.0	7-65	0.55	M2.9-M6.4	M2.6-M5.4	72	10pcs/10kg/11kg/0.75'
WX-3T60PBE	550	790	215	37	8.0	15-95	0.55	M4.1-M7.0	M3.1-M6.0	72	10pcs/10kg/11kg/0.75'
WX-3T65PBE	300	810	215	37	8.0	30-180	0.55	M5.0-M9.3	M4.0-M7.2	72	10pcs/10kg/11kg/0.75'
WX-3T68PBE	250	810	215	37	8.0	50-280	0.55	M6.0-M11.0	M4.9-M8.7	72	10pcs/10kg/11kg/0.75'

● Air Pressure / 空氣壓力 : 90 Psi (6.2 bar)

● Standard Deviation / 扭力精度 : ±3 %



# Shut Off Screwdriver



WX-3T-AB Series



WX-3R-PBP Series



WX-3R-BBP Series

Lever Start Shut off - Angle type / 彎頭壓板式全自動氣動起子

Model	Free Speed	Weight	Length	Dia	Air Hose Size	Torque Range	Air cons.	Fastening Capacity		Noise	Packing
型號	轉速	重量	長度	把手外徑	進氣管尺寸	扭力範圍	空氣耗氣量	機械螺絲	自攻螺絲	噪音值	包裝明細 (CTN)
	RPM	g	mm	mm	mm	Kgf-cm	m <sup>3</sup> /min	基準T	2.0T	dB (A)	PCS/N.W./G.W./CUFT
WX-3T20AB	1,000	660	270	29	5.0	1-8	0.28	M1.7-M3.3	M1.3-M2.7	67	10pcs/9kg/10kg/0.83'
WX-3T30AB	1,800	660	270	29	5.0	3-17	0.28	M2.2-M4.2	M1.7-M3.2	67	10pcs/9kg/10kg/0.83'
WX-3T35AB	2,200	660	270	29	5.0	3-20	0.28	M2.2-M4.5	M1.7-M3.5	67	10pcs/9kg/10kg/0.83'
WX-3T40AB	1,000	660	270	29	5.0	5-30	0.28	M2.8-M5.0	M2.2-M4.0	67	10pcs/9kg/10kg/0.83'
WX-3T45AB	800	660	270	29	8.0	8-40	0.28	M3.3-M5.7	M2.7-M4.4	67	10pcs/9kg/10kg/0.83'
WX-3T48AB	1,800	1,200	345	37	8.0	5-45	0.55	M2.8-M5.8	M2.2-M4.7	72	10pcs/14kg/15kg/0.83'
WX-3T50AB	1,400	1,200	345	37	8.0	7-50	0.55	M2.9-M6.0	M2.6-M4.9	72	10pcs/14kg/15kg/0.83'
WX-3T55AB	1,000	1,200	345	37	8.0	7-65	0.55	M2.9-M6.4	M2.6-M.4	72	10pcs/14kg/15kg/0.83'
WX-3T60AB	550	1,200	345	37	8.0	15-95	0.55	M4.1-M7.0	M3.1-M6.0	72	10pcs/14kg/15kg/0.83'
WX-3T65AB	300	1,400	345	37	8.0	30-180	0.55	M5.0-M9.3	M4.0-M7.2	72	10pcs/14kg/15kg/0.83'
WX-3T68AB	250	1,400	345	37	8.0	50-280	0.55	M6.0-M11.0	M4.9-M8.7	72	10pcs/14kg/15kg/0.83'

Push or Push-Trigger start shut off - Pistol Type / 槍型下壓按鈕式全自動氣動起子

Model	Free Speed	Weight	Length	Dia	Air Hose Size	Torque Range	Air cons.	Fastening Capacity		Noise	Packing
型號	轉速	重量	長度	把手外徑	進氣管尺寸	扭力範圍	空氣耗氣量	機械螺絲	自攻螺絲	噪音值	包裝明細 (CTN)
	RPM	g	mm	mm	mm	Kgf-cm	m <sup>3</sup> /min	基準T	2.0T	dB (A)	PCS/N.W./G.W./CUFT
WX-3R35PBP	2,200	950	215	31	6.35	3-20	0.55	M2.4-M4.5	M2.0-M3.5	72	10pcs/8kg/9kg/1.18'
WX-3R38PBP	1,800	950	215	31	6.35	3-25	0.55	M2.4-M4.7	M2.0-M3.8	72	10pcs/8kg/9kg/1.18'
WX-3R41PBP	1,000	950	215	31	6.35	5-35	0.55	M2.8-M5.2	M2.2-M4.2	72	10pcs/8kg/9kg/1.18'
WX-3R47PBP	550	950	215	31	6.35	10-50	0.55	M3.6-M6.0	M2.8-M4.7	72	10pcs/8kg/9kg/1.18'
WX-3R48PBP	1,800	950	215	31	9.5	7-50	0.55	M2.8-M6.0	M2.3-M4.9	72	10pcs/12kg/13kg/1.18'
WX-3R50PBP	1,400	950	215	39	9.5	10-60	0.55	M2.9-M6.2	M2.6-M5.1	72	10pcs/12kg/13kg/1.18'
WX-3R55PBP	1,000	950	215	39	9.5	12-75	0.55	M3.5-M6.6	M2.3-M5.5	72	10pcs/12kg/13kg/1.18'
WX-3R60PBP	550	950	215	39	9.5	30-110	0.55	M5.0-M7.3	M3.3-M6.2	72	10pcs/12kg/13kg/1.18'
WX-3R65PBP	300	950	215	39	9.5	30-180	0.55	M5.0-M9.3	M3.3-M7.2	72	10pcs/12kg/13kg/1.18'
WX-3R68PBP	250	1,100	215	39	9.5	50-280	0.6	M5.0-M11.0	M3.3-M8.7	78	10pcs/12kg/13kg/1.18'

Trigger Start Shut Off - Pistol Type / 槍型按鈕式全自動氣動起子

Model	Free Speed	Weight	Length	Dia	Air Hose Size	Torque Range	Air cons.	Fastening Capacity		Noise	Packing
型號	轉速	重量	長度	把手外徑	進氣管尺寸	扭力範圍	空氣耗氣量	機械螺絲	自攻螺絲	噪音值	包裝明細 (CTN)
	RPM	g	mm	mm	mm	Kgf-cm	m <sup>3</sup> /min	基準T	2.0T	dB (A)	PCS/N.W./G.W./CUFT
WX-3R35BBP	2,200	950	215	31	6.35	3-20	0.55	M2.4-M4.5	M2.0-M3.5	72	10pcs/8kg/9kg/1.18'
WX-3R38BBP	1,800	950	215	31	6.35	3-25	0.55	M2.4-M4.7	M2.0-M3.8	72	10pcs/8kg/9kg/1.18'
WX-3R41BBP	1,000	950	215	31	6.35	5-35	0.55	M2.8-M5.2	M2.2-M4.2	72	10pcs/8kg/9kg/1.18'
WX-3R47BBP	550	950	215	31	6.35	10-50	0.55	M3.6-M6.0	M2.8-M4.7	72	10pcs/8kg/9kg/1.18'
WX-3R48BBP	1,800	950	215	31	9.5	7-50	0.55	M2.8-M6.0	M2.3-M4.9	72	10pcs/12kg/13kg/1.18'
WX-3R50BBP	1,400	950	215	39	9.5	10-60	0.55	M2.9-M6.2	M2.6-M5.1	72	10pcs/12kg/13kg/1.18'
WX-3R55BBP	1,000	950	215	39	9.5	12-75	0.55	M3.5-M6.6	M2.3-M5.5	72	10pcs/12kg/13kg/1.18'
WX-3R60BBP	550	950	215	39	9.5	30-110	0.55	M5.0-M7.3	M3.3-M6.2	72	10pcs/12kg/13kg/1.18'
WX-3R65BBP	300	950	215	39	9.5	30-180	0.55	M5.0-M9.3	M3.3-M7.2	72	10pcs/12kg/13kg/1.18'
WX-3R68BBP	250	1,100	215	39	9.5	50-280	0.6	M5.0-M11.0	M3.3-M8.7	78	10pcs/13kg/14kg/1.18'

• Air Pressure / 空氣壓力 : 90 Psi (6.2 bar)

• Standard Deviation / 扭力精度 : ±3 %



There is omnipotent hold fast. It's easy to clip firmly in various of thickness on process tools of plane surface. It can purge hardened surface of metal that made from discharge electricity quickly. Long life, high speed, light weight and trouble free.

專利之萬用夾頭組，可輕易地穩固夾住各種厚度的平面加工用工具，如各型油石、各型砂紙夾以及柄是平面的各式銼刀。可迅速去除因放電加工或線切割加工後，金屬表面所產生的硬化表層。壽命長、速度快、重量輕、無故障。



WX-450

**Standard Accessory**

Switch Connector  
Rat Tail File  
Triangular Taper File  
Flat Bastard File

**Option**

Half Round File

**標準配件**

轉接頭 (5mm>3mm) (No.345000390)  
圓銼刀 (No.345000321)  
三角銼刀 (No.345000322)  
平銼刀 (No.345000324)

**選配件**

半圓銼刀 (No.345000323)

Model 型號	Stroke 衝程	Free Speed 衝擊速	Air Cons. @Load 負載中耗氣量	Length 長度	Weight 重量	Noise 噪音值	Packing 包裝明細 (CTN)
	mm	spm	cfm (l/min)	mm	kg	dB (A)	PCS/N.W./G.W./CUFT
WX-450	5	3,400	7 (198)	800	0.52	73	10pcs/8kg/9kg/0.7'

• Air Inlet / 進氣口尺寸 : 1/4" PT or NPT

• Min. Hose Size / 進氣管尺寸 : 1/4" (6.35mm)

• Air Pressure / 空氣壓力 : 90 psi (6.2bar)



WX-451

**Standard Accessory 標準配件**

Rat Tail File 圓銼刀  
Triangular Taper File 三角銼刀  
Half Round File 半圓銼刀  
Flat Bastard File 平銼刀

Model 型號	Stroke 衝程	Free Speed 衝擊速	Air Cons. @Load 負載中耗氣量	Length 長度	Weight 重量	Noise 噪音值	Packing 包裝明細 (CTN)
	mm	spm	cfm (l/min)	mm	kg	dB (A)	PCS/N.W./G.W./CUFT
WX-451	10	3,700	1 (28)	180	1	85	10pcs/11 kg/12 kg/0.8'

• Air Inlet / 進氣口尺寸 : 1/4" PT or NPT

• Min. Hose Size / 進氣管尺寸 : 1/4" (6.35mm)

• Air Pressure / 空氣壓力 : 90 psi (6.2bar)

# Air Hammer



WS-402-190



WS-402-250



WX-436

## WS-402-190K/402-250K

### Standard Accessory 標準配件

1. Air Hammer / 氣動錘 x 1 pc.
  2. Spring Retainer / 承盤彈簧 x 1pc
  3. 175L chisels / 鑿刀 x 5 pcs.
  4. Mini Oiler / 注油器 x 1pc.
  5. Oil Pot / 油壺 x 1pc.
  6. Blow case / 吹氣盒 x 1 pc.
- Packing/包裝明細：5pcs/16 kg/17 kg/1.6'



## WS-402-190SK/402-250SK

### Standard Accessory 標準配件

1. Air Hammer / 氣動錘 x 1 pc.
  2. Quick Retainer / 快速接頭 x 1pc
  3. 175L chisels / 鑿刀 x 4 pcs.
  4. Blow case / 吹氣盒 x 1 pc.
- Packing / 包裝明細：5pcs/18 kg/19 kg/1.6'



Model	Bore Diameter	Stroke Length	Blows Per Min.	Air Cons. @Load	Length	Weight	Noise	Packing
型號	活塞直徑	活塞衝程	衝擊頻率	負載中耗氣量	長度	重量	噪音值	包裝明細 (CTN)
	inch (mm)	inch (mm)	B.P.M	cfm (l/min)	mm	kg	dB (A)	PCS/N.W./G.W./CUFT
WS-402-190	3/4" (19)	2-5/8" (66)	3,200	7.4 (210)	180	2	101.5	10pcs/24.5 kg/25.5 kg/1'
WS-402-250	3/4" (19)	3-5/8" (92)	2,000	7.1 (200)	230	2	102.1	10pcs/28.2 kg/29.2 kg/1'
WX-436	22mm	22mm	4,000	8.83 (250)	187	1	95	20pcs/29kg/30kg/1.2'

• Air Pressure / 空氣壓力：90 psi (6.2bar)

• Min. Hose Size / 進氣管尺寸：3/8" (9.5mm)

• Air Inlet / 進氣口尺寸：1/4" PT or NPT

# Needle Scaler

Needle Scaler and Flux Chipper it's powerful for exerting and chisel is suitable to dismantle. It's was designed specially to use for a long time. And suitable for boat, machine and large instrument to clear off the rust and adhesion underside.

體積小、出力大，適用於各類除細物、除鏽、除著物等作業。  
鑿刀適合於瓷磚之拆除作業，適用船艙、重機械等之底部除鏽、除附著物或一般工廠之大型工具翻修時之除鏽作業。



WX-430



WX-431



WX-430S

Model 型號	Free Speed 無負載轉速	Length 長度	Weight 重量	Air Cons. 工作耗氣量	Noise 噪音值	Packing 包裝明細 (CTN)
	b/min	mm	kg	cfm (l/min)	dB (A)	PCS/N.W./G.W./CUFT
WX-430	3,000	385	2.59	7 (200)	95	5pcs/14kg/14.5kg/0.4'
WX-431	3,000	333	2.67	7 (200)	97	5pcs/14kg/15kg/0.7'
WX-430S	4,000	310	1.06	6.35 (180)	91	5pcs/6kg/7kg/0.4'

• Air Inlet / 進氣口尺寸 : 1/4" PT or NPT

• Min. Hose Size / 進氣管尺寸 : 1/4" (6.35mm)

• Air Pressure / 空氣壓力 : 90 psi (6.2bar)

# Flux Chipper

**Standard Accessory 標準配件**  
Flat Chisel 平鑿刀 (No. 349940306)

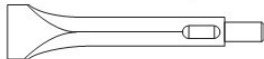

WX-430A

**Option 選配件**  
Tip Chisel 尖鑿刀 (No. 349901070)



WX-431A



WX-430AS

Model 型號	Free Speed 無負載轉速	Length 長度	Weight 重量	Air Cons. 工作耗氣量	Noise 噪音值	Packing 包裝明細 (CTN)
	b/min	mm	kg	cfm (l/min)	dB (A)	PCS/N.W./G.W./CUFT
WX-430A	3,000	230	1.79	7 (200)	88	5pcs/13.5kg/14.5kg/0.4'
WX-431A	3,000	203	1.69	7 (200)	92	5pcs/11.5kg/12.5kg/0.7'
WX-430AS	4,000	290	1.10	6.35 (180)	91	5pcs/6kg/7kg/0.4'

• Air Inlet / 進氣口尺寸 : 1/4" PT or NPT

• Min. Hose Size / 進氣管尺寸 : 1/4" (6.35mm)

• Air Pressure / 空氣壓力 : 90 psi (6.2bar)



# Air Chipper Hammer

## OPTION 選配件



### Quick Connector

快速接頭

342090100

FOR WX-420~WX-422



WX-420C



WX-421



WX-422

Model 型號	Chisel Shank		Piston Diameter 活塞直徑	Piston stroke 活塞行程	Blow Per Min 衝擊頻率	Length 長度	Weight 重量	Air Cons. 工作耗氣量	Noise 噪音值	Packing 包裝明細 (CTN)
	Round 圓形尺寸	Hex 六角尺寸								
	inch (mm)	inch (mm)	mm	mm (inch)	B.P.M	mm	kg	cfm (L/min)	dB (A)	PCS/N.W./G.W./CUFT
WX-420C	0.55 (14)	0.47 (12)	20	65 (2.56)	3,000	243	2.6	11.4 (320)	97.4	10pcs/30kg/31.5kg/1.45'
WX-421	0.68 (17.3)	0.58 (14.7)	29	91.7 (3.6)	2,400	400	7	10 (280)	91.17	2pcs/13.8kg/15.9kg/1'
WX-422	0.68 (17.3)	0.58 (14.7)	29	102 (4.02)	1,500	470	8.3	7.12 (200)	91.71	2pcs/16.3kg/19kg/1.08'

• Air Inlet / 進氣口尺寸 : 1/4" PT or NPT

• Min. Hose Size / 進氣管尺寸 : 1/2" (12.7mm)

• Air Pressure / 空氣壓力 : 90 psi (6.2bar)

Inside Trigger is available for all models.

所有機型開關皆可改為內板機。



WX-425



WX-426



WX-428

Model 型號	Chisel Shank		Piston Diameter 活塞直徑	Piston stroke 活塞行程	Blow Per Min 衝擊頻率	Length 長度	Weight 重量	Air Cons. 工作耗氣量	Noise 噪音值	Packing 包裝明細 (CTN)
	Round 圓形尺寸	Hex 六角尺寸								
	inch (mm)	inch (mm)	mm	mm (inch)	B.P.M	mm	kg	cfm (L/min)	dB (A)	PCS/N.W./G.W./CUFT
WX-425	0.68 (17.3)	0.58 (14.7)	28	46 (1.81)	2,490	390	5.4	10.7(300)	101	2pcs/11.8kg/12.5kg/1'
WX-426	0.68 (17.3)	0.58 (14.7)	29	77 (3.03)	3,600	365	8.04	11.4(320)	96	2pcs/16kg/17.6kg/0.95'
WX-427	0.68 (17.3)	0.58 (14.7)	29	94 (3.7)	2,280	400	8.5	11.4(320)	95.9	2pcs/16.8kg/18.5kg/1.01'
WX-428	0.68 (17.3)	0.58 (14.7)	29	102 (4.02)	1,800	425	8.88	11.7(330)	98.7	2pcs/17.8kg/19.6kg/1.07'

• Air Inlet / 進氣口尺寸 : 3/8" PT or NPT

• Min. Hose Size / 進氣管尺寸 : 1/2" (12.7mm)

• Air Pressure / 空氣壓力 : 90 psi (6.2bar)

# Air Rivet Hammer

Used and installed on production run.  
適用於生產線安裝。

## WX-435

C cotter pin with Dia. 2~6Ømm hole,  
tightness tolerance : 0~0.2mm  
C型銷直徑2~6Ømm孔、緊度0~0.2mm



WX-435  
Pin Less

### Standard Accessory 標準配件

- 343501800 (Φ6)
- 343501900 (for Riveting 鉚釘用)
- 343502000 (Φ3)

## WX-439A.439B

C cotter pin with Dia. 2~6Ømm hole,  
tightness tolerance : 0.2~0.5mm  
C型銷直徑2~6Ømm孔、緊度0.2~0.5mm



C cotter pin C型開口銷  
3439A9050

WX-439A



3mm Tungsten steel flat head  
平面鎢鋼頭 3439B9020

WX-439B

Model 型號	Chisel Shank		Piston Diameter 活塞直徑 mm	Piston stroke 活塞行程 mm (inch)	Blow Per Min 衝擊頻率 B.P.M	Length 長度 mm	Weight 重量 kg	Air Cons. 工作耗氣量 cfm (L/min)	Noise 噪音值 dB (A)	Packing 包裝明細 (CTN) PCS/N.W./G.W./CUFT
	Round 圓形尺寸 inch (mm)	Hex 六角尺寸 inch (mm)								
WX-435	5/16 (8.0)	N/A	10	30 (1.18)	5,400	170	0.4	3 (85)	90	20pcs/14kg/15kg/0.81'
WX-439A.B	1/2 (12.7)	N/A	25	33 (1.30)	5,000	211	1.75	7 (198)	98	10pcs/18kg/19kg/0.5'

• Air Inlet / 進氣口尺寸 : 1/4" PT or NPT

• Min. Hose Size / 進氣管尺寸 : 3/8" (9.5mm)

• Air Pressure / 空氣壓力 : 90 psi (6.2bar)

## Special "S" shape Pistol Type

特殊S型槍型



WX-413G

Model 型號	Chisel Shank 尺寸 inch	Piston Diameter 活塞直徑 mm (in)	Piston stroke 活塞行程 mm (inch)	Blow Per Min 衝擊頻率 B.P.M	Rivet Nuts		Length 長度 mm	Weight 重量 kg	Air Cons. 工作耗氣量 cfm (L/min)	Noise 噪音值 dB (A)	Packing 包裝明細 (CTN) PCS/N.W./G.W./CUFT
					Steel 鐵金屬 inch	Alum 鋁合金 inch					
wx-413G	0.4	12.7 (1/2)	73 (2-7/8)	2,160	5/32"	3/16"	231	2.16	17.7 (500)	95.8	6pcs/14.1kg/14.9kg/1'

• Air Inlet / 進氣口尺寸 : 1/4" PT or NPT

• Min. Hose Size / 進氣管尺寸 : 3/8" (9.5mm)

• Air Pressure / 空氣壓力 : 90 psi (6.2bar)

# Air Rivet Hammer

## Straight Type

直型



WX-411S



WX-412S

### OPTION 選配件



**Quick Connector**  
快速接頭 341290100  
FOR WX-412~WX-414



**Quick Connector**  
快速接頭 341590100  
FOR WX-415~WX419

Model 型號	Chisel Shank 尺寸	Piston Diameter 活塞直徑	Piston stroke 活塞行程	Blow Per Min 衝擊頻率	Rivet Nuts Steel 鐵金屬	Alum 鋁合金	Length 長度	Weight 重量	Air Cons. 工作耗氣量	Noise 噪音值	Packing 包裝明細 (CTN)
	inch	mm (inch)	mm (inch)	B.P.M	inch	inch	mm	kg	cfm (L/min)	dB (A)	PCS/N.W./G.W./CUFT
WX-411S	0.4	14.3 (9/16")	35 (1-3/8")	2,850	3/32"	1/8"	150	0.86	10.59 (300)	95.1	10pcs/9kg/10.5kg/0.7'
WX-412S	0.4	12.7 (1/2")	57.2 (2-1/4")	2,580	3/32"	1/8"	185	1.26	17.7 (500)	95.1	10pcs/10.5kg/12kg/0.7'
WX-413S	0.4	12.7 (1/2")	73 (2-7/8")	2,160	5/32"	3/16"	216	1.16	14.4 (410)	95.8	10pcs/11.5kg/13kg/0.7'
WX-412S	0.4	12.7 (1/2")	77.8 (3-1/16")	2,300	3/16"	1/4"	228	1.27	13.06 (370)	95.8	10pcs/12.5kg/14kg/0.82'

## Pistol Type

槍型



WX-411P



WX-413P



WX-415P

X: Power / 強力

Model 型號	Chisel Shank 尺寸	Piston Diameter 活塞直徑	Piston stroke 活塞行程	Blow Per Min 衝擊頻率	Rivet Nuts Steel 鐵金屬	Alum 鋁合金	Length 長度	Weight 重量	Air Cons. 工作耗氣量	Noise 噪音值	Packing 包裝明細 (CTN)
	inch	mm (inch)	mm (inch)	B.P.M	inch	inch	mm	kg	cfm (L/min)	dB (A)	PCS/N.W./G.W./CUFT
WX-411P	0.4	14.3 (9/16")	35 (1-3/8")	2,850	3/32"	1/8"	160	0.86	10.59 (300)	95.1	10pcs/10.5kg/13kg/1.16'
WX-412P	0.4	12.7 (1/2")	57.2 (2-1/4")	2,580	3/32"	1/8"	170	1.06	17.7 (500)	95.8	10pcs/12kg/15.5kg/1.16'
WX-413P	0.4	12.7 (1/2")	73 (2-7/8")	2,160	5/32"	3/16"	186	1.36	14.4 (410)	95.8	10pcs/13kg/16.5kg/1.16'
WX-413PX	0.4	14.3 (9/16")	73 (2-7/8")	2,160	5/32"	3/16"	170	1.36	17.7 (500)	95.1	10pcs/13kg/16.5kg/1.16'
WX-414P	0.4	12.7 (1/2")	77.8 (3-1/16")	1,740	3/16"	1/4"	211	1.39	13.06 (370)	95.8	10pcs/14kg/17.5kg/1.16'
WX-414PX	0.4	14.3 (9/16")	77.8 (3-1/16")	1,740	3/16"	1/4"	211	1.39	13.06 (370)	95.1	10pcs/14kg/17.5kg/1.16'
WX-415P	0.5	19 (3/4")	68.3 (2-11/16")	1,600	3/16"	1/4"	230	2.1	18.3 (520)	95.44	10pcs/22kg/26kg/1.66'
WX-417P	0.5	19 (3/4")	98.4 (3-7/8")	1,140	1/4"	5/16"	256	2.4	18.3 (520)	95.3	10pcs/24kg/28kg/1.66'
WX-419P	0.5	19 (3/4")	147.6 (5-13/16")	900	5/16"	3/8"	284	2.5	26.8 (760)	94.1	10pcs/26.5kg/30.5kg/1.16'

























• Air Inlet / 進氣口尺寸 : 1/4" PT or NPT

• Min. Hose Size / 進氣管尺寸 : 3/8" (9.5mm)

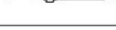
• Air Pressure / 空氣壓力 : 90 psi (6.2bar)



# Rivet Hammer Chisels

	Model	Spec.						Memo
	型號	後軸外徑 (mm)		後軸長度 A	前軸外徑 d	前軸尺寸	長度	備註
		Round	Hex	mm	mm	Inch (mm)	mm	
	349940100		14.7	60	20		255-260	WX-421.422.425.426.428用
	349930100	17		60	20		255-260	WX-421.422.425.426.428用
	349940300		14.7	60	20	30mm	255-260	WX-421.422.425.426.428用
	349930300	17		60	20		255-260	WX-421.422.425.426.428用
	349940400		14.7	60	20	50mm	255-260	WX-421.422.425.426.428用
	349930400	17		60	20	50mm	255-260	WX-421.422.425.426.428用
	349970400	13.8		45	16	30mm	250	WX-420C用
	349950100	10.8		45	12	3/16" (4.8)	85-90	WX-412.413.414用
	349950200	10.8		45	12	5/32" (4.0)	85-90	WX-412.413.414用
	349950300	10.8		45	12	1/8" (3.2)	85-90	WX-412.413.414用
	349950400	10.8		45	12	3/32" (2.4)	85-90	WX-412.413.414用
	349950500	10.8		45	12	1" (25.4)	31	WX-412.413.414用
	349952000	10.8		13.6	12.6	3/16"	31	WX-411P専用
	349952100	10.8		13.6	12.6	5/32"	31	WX-411P専用
	349952200	10.8		13.6	12.6	1/8"	31	WX-411P専用
	349952300	10.8		13.6	12.6	3/23"	31	WX-411P専用
	349952400	10.8		13.6	16	1"	30	WX-411P専用
	349960100	12.6		45	16	3/32" (2.4)	100	WX-415.417.419用
	349960200	12.6		45	16	1/8" (3.2)	100	WX-415.417.419用
	349960300	12.6		45	16	5/32" (4.0)	100	WX-415.417.419用
	349960400	12.6		45	16	3/16" (4.8)	100	WX-415.417.419用
	349960500	12.6		45	16	1/4" (6.35)	100	WX-415.417.419用
	349960600	12.6		45	16	5/16" (7.9)	100	WX-415.417.419用
	349960700	12.6		45	16	1-1/4" (32)	100	WX-415.417.419用

# One Shot Hammer

One shot hammer is good for environments of low air consumption and precise work, for instance, the assembly of pins, bushings, bearing collars and oil seals....each hit is able to deliver accurate power.

單擊式氣錘，適用於低耗氣量且需精準工作的環境，例如：插銷、襯套、軸承環、油封等物件的組裝。每一次的打擊都能提供精確的打擊力道。



WX-437



WX-438

## Standard Accessory 標準配件



349980100  
Round, L : 85mm, W : 19.9mm

## Option 選配件



349980200  
Hex., L : 85mm, W : 19.9mm



3499031B70  
Hex., L : 165mm, W : 11.8mm



3499031A70  
Round, L : 165mm, W : 11.8mm

Model 型號	Power 力量	Length 長度	Weight 重量	Air Inlet 進氣口尺寸	Air Cons. 工作耗氣量	Noise 噪音值	Packing 包裝明細 (CTN)
	Nm	mm	Kg	inch	cm <sup>3</sup> /stroke	dB (A)	PCS/N.W./G.W./CUFT
WX-437	2.25	213	1	1/4"	220	85.4	10pcs/12.4kg/12.9kg/0.82'
WX-438	3.1	254	1.2	1/4"	220	86.3	10pcs/14kg/14.5kg/0.82'

• Min. Hose Size / 進氣管尺寸 : 1/4" (6.35mm)

• Air Pressure / 空氣壓力 : 90 psi (6.2bar)

# Air Valve Lapper

## WS-405/405K



WS-405

Sucker : 16 / 20 / 30 / 35mm



### WS-405K

1. Sucker / 吸盤 x 4pcs (16/20/30/35mm)
  2. Blow Case / 吹氣盒 x 1pc
- Packing / 包裝明細 : 5pcs/10.1kg/11.1kg/0.81'

Model 型號	Valve Capacity 適用汽門直徑	Blows Per Min 衝擊頻率	Air Cons. 工作耗氣量	Length 長度	Weight 重量	Noise 噪音值	Packing 包裝明細 (CTN)
	inch (mm)	BPM	cfm (l/min)	mm	kg	dB (A)	PCS/N.W./G.W./CUFT
WS-405	1-3/4" (45)	3,000	3.53 (100)	153.5	1.55	85	12pcs/20kg/21kg/0.91'

• Air Inlet / 進氣口尺寸 : 1/4" PT or NPT

• Min. Hose Size / 進氣管尺寸 : 1/4" (6.35mm)

• Air Pressure / 空氣壓力 : 90 psi (6.2bar)

## WS-601K

This high quality simple tool can quickly and effectively grinds valves in seconds.



### Standard Accessory 標準配件

1. Sucker / 吸盤 x 5pcs (16/20/30/35/45mm)
2. Hex. Wrench / 六角板手 x 1pc
3. Shaft / 吸盤軸 x 5pcs
4. Blow Case / 吹氣盒 x 1pc

**WS-601K is not allowed to resell in Thailand, Malaysia, Singapore as we have sole agent there.**  
**WS-601K 禁止販售於泰國、馬來西亞以及新加坡地區。**

Model 型號	Valve Capacity 適用汽門直徑	Blows Per Min 衝擊頻率	Air Cons. 工作耗氣量	Length 長度	Weight 重量	Noise 噪音值	Packing 包裝明細 (CTN)
	inch (mm)	BPM	cfm (l/min)	mm	kg	dB (A)	PCS/N.W./G.W./CUFT
WS-601K	1-3/4" (45)	800	1.77 (50)	289.1	0.65	82	5pcs/10.5kg/11.5kg/2.6'

• Air Inlet / 進氣口尺寸 : 1/4" PT or NPT

• Min. Hose Size / 進氣管尺寸 : 1/4" (6.35mm)

• Air Pressure / 空氣壓力 : 90 psi (6.2bar)



- For automobile maintenance and Carriage industry, especially for produce line and repair, steel plates to be connected.
- To replace electric-welding, fast and powerful in work.
- A accurate pneumatic motor with long service life.
- Two switches design and convenient operation.

- 適合生產線與維修用，可與薄板與薄板結合聯結用，適合車箱工業與汽車維修用。
- 可取代電銲結合，強度高，施工快速。
- 氣動馬達高精度，高使用壽命。
- 雙開關設計，操作方便。



#### OPTION 選配件



Curve Head / 弧形拉帽頭  
Design for curve surface connection  
適用U型曲面

#### WARN 注意事項

Operating Pressure 拉桿工作氣壓值

M3 : 25 Psi

M4 : 45 Psi

M5 : 75 Psi

M6~M12 : 90~100 Psi



797009200  
Regulator / 調壓閥



#### Standard Accessory 標準配件

1. Head / 拉帽頭 : M3\*1, M4\*1, M5\*1, M6\*1, M8\*1, M10\*1(on the tool), M12\*1
2. Ring Nut / 拉帽頭螺帽 \*7
3. Tie Rod / 拉桿: M3\*2, M4\*2, M5\*2, M6\*1, M8\*1, M10\*1(on the tool), M12\*1
4. Stroke Regulator / 行程調節桿\*1
5. Hex. Wrench / 六角板手\*1
6. Spanner / 開口板手 \*1
7. Regulator / 調壓閥 \* 1
8. Blow Case / 吹氣盒 \*1

Model 型號	Rivet Nut Capacity 拉帽能力	Stroke 行程	Max Power 最大拉力	Length 長度	Weight 重量	Air Cons 工作耗氣量	Vibrations 震動值	Noise 噪音值	Packing 包裝明細 (CTN)
	mm	mm	kg	mm	kg	l/min	m/s <sup>2</sup>	dB (A)	PCS/N.W./G.W./CUFT
WS-515	M3~M12	0-6.5mm	2142	310	2.5	7.5	<2.5	<80	1pc/5kg/5.7kg/1' 2pcs/9kg/10kg/2'

- Air Inlet / 進氣口尺寸 : 1/4" PT or NPT

## Pistol Type 槍型

Quick Change 快脫



Full Cage Gear Design.

全包式齒輪設計。

Model 型號	Rivet Nut Capacity 拉帽能力	Free Speed 無負載轉速	Length 長度	Weight 重量	Noise 噪音值	Packing 包裝明細 (CTN)
	mm	RPM	mm	kg	dB (A)	PCS/N.W./G.W./CUFT
WX-516B	M3-M5	2,100	202	1.27	92.8	10pcs/13kg/15kg/0.98'
WX-517B	M6-M8	800	222	1.56	94.8	10pcs/17kg/18kg/0.98'
WX-518B	M8-M10	500	233	1.56	93.1	10pcs/17kg/18kg/0.98'
WX-519B	M10-M12	350	245	1.64	92.8	10pcs/18kg/19kg/0.98'

• Air Cons. / 工作耗氣量 : 10 cfm (285 L/min)

• Min. Hose Size / 進氣管尺寸 : 3/8" (9.5mm)

• Air Inlet / 進氣口尺寸 : 1/4" PT or NPT

• Air Pressure / 空氣壓力 : 35-90 psi

## Straight 直型/Angle Type 彎型

Quick Change 快脫



WX-531B / 532B



WX-541B / 542B

Model 型號	Rivet Nut Capacity 拉帽能力	Free Speed 無負載轉速	Length 長度	Weight 重量	Noise 噪音值	Packing 包裝明細 (CTN)
	mm	RPM	mm	kg	dB (A)	PCS/N.W./G.W./CUFT
WX-531B	M5-M6	1,500	220	1.1	92.1	12pcs/18kg/19kg/1.1'
WX-532B	M8-M10	600	220	1.1	92.1	12pcs/18kg/19kg/1.1'
WX-541B	M5-M6	1,100	220 x 100	1.1	89.5	10pcs/19kg/20kg/2'
WX-542B	M8-M10	600	220 x 100	1.1	89.5	10pcs/19kg/20kg/2'

• Air Cons. / 工作耗氣量 : 4.94 cfm (140 L/min)

• Min. Hose Size / 進氣管尺寸 : 3/8" (9.5mm)

• Air Inlet / 進氣口尺寸 : 1/4" PT or NPT

• Air Pressure / 空氣壓力 : 100 psi (6.9bar)

# Tapping Tool



WX-523

Full Cage Gear Design.

全包式齒輪設計。

Model 型號	Tapping Capacity 攻牙能力		Free Speed 無負載轉速 RPM	Air Cons. 工作耗氣量 cfm (l/min)	Length 長度 mm	Weight 重量 kg	Noise 噪音值 dB (A)	Packing 包裝明細 (CTN) PCS/N.W./G.W./CUFT
	Alum./Cu 鋁/銅 mm	Iron 鐵 mm						
WX-523	6~12	6~10	350	10 (283)	215	1.6	93	10pcs/16kgs/18.5kgs/0.98'

• Air Inlet / 進氣口尺寸 : 1/4" PT or NPT

• Min. Hose Size / 進氣管尺寸 : 3/8" (9.5mm)

• Air Pressure / 空氣壓力 : 90 psi (6.2 bar)

# Tapping Tool w/Extension Arm 手臂式攻牙機



WX-582PK



WX-583K



WX-584K

Model 型號	Tapping Capacity 攻牙能力 mm	Free Speed 無負載轉速 RPM	Air Cons. 工作耗氣量 cfm (l/min)	Extension Arm 延伸臂		Tapper Bit Holder 牙攻束緊夾頭 mm	Memo 備註
				Holding Cap. 乘載力 mm	Extended Span Length 延伸長度 mm		
WX-582PK	3~12	400	3.22 (91)	Max.12	90-980	5, 6, 8, 10, 12	W/Comfort Grip Full Cage Gear System B12 Spindle Taper
WX-583K	6~24	250 + 90	4.48 (127)	Max.24	100-1,050	6, 8, 10, 12, 16, 24	Two Speed Full Cage Gear System B18 Spindle Taper
WX-584K	8~16	250	4.48 (127)	Max.24	100-1,050	8, 10, 12, 16	Full Cage Gear System B16 Spindle Taper

• Air Inlet / 進氣口尺寸 : 1/4" PT or NPT

• Min. Hose Size / 進氣管尺寸 : 3/8" (9.5mm)

• Air Pressure / 空氣壓力 : 90 psi (6.2 bar)



## Pistol Type

槍型



WS-525 (Full Cage)



WX-526 / 527 (Full Cage)



WX-528 / 529 (Full Cage)



WX-504R

Model 型號	Reversible 正逆轉	Chuck Size 夾頭尺寸	Free Speed 無負載轉速	Air Cons 工作耗氣量	Length 長度	Weight 重量	Noise 噪音值	Packing 包裝明細 (CTN)
		inch (mm)	RPM	cfm (l/min)	mm	kg	dB (A)	PCS/N.W./G.W./CUFT
WS-525	NO	3/8" (9.5)	5,000	7 (200)	150	0.98	90.9	10pcs/14.3 kg/15.3 kg/1'
WX-526	YES	3/8" (9.5)	2,100	10 (285)	185	1.24	93	10pcs/14 kg/15 kg/1'
WX-527	YES	3/8" (9.5)	3,000	10 (285)	185	1.24	93	10pcs/19 kg/20 kg/1'
WX-502R	YES	3/8" (9.5)	2,300	10.68 (300)	191	1.3	87.6	10pcs/19 kg/20 kg/1'
WX-528	YES	1/2" (12.7)	500	10 (285)	220	1.76	94	20pcs/18 kg/19 kg/1'
WX-529	YES	1/2" (12.7)	800	10 (285)	220	1.76	94	10pcs/12 kg/13 kg/0.83'
WX-504R	YES	1/2" (12.7)	600	10.68 (300)	240	1.75	96.3	20pcs/18 kg/19 kg/1'

## Straight 直型/Angle Type 彎頭型



WX-506 / 507



WX-521

Model 型號	Reversible 正逆轉	Chuck Size 夾頭尺寸	Free Speed 無負載轉速	Air Cons 工作耗氣量	Length 長度	Weight 重量	Noise 噪音值	Packing 包裝明細 (CTN)
		inch (mm)	RPM	cfm (l/min)	mm	kg	dB (A)	PCS/N.W./G.W./CUFT
WX-506	NO	3/8" (9.5)	2,500	10.5 (298)	215	0.89	82.1	20pcs/18 kg/21 kg/0.88'
WX-507	NO	3/8" (9.5)	4,000	10.5 (298)	215	0.89	84.9	20pcs/18 kg/21 kg/0.88'
WX-521	YES	3/8" (9.5)	1,600	8 (226)	215	1.12	92.5	10pcs/12 kg/14 kg/0.55'

• Air Inlet / 進氣口尺寸 : 1/4" PT or NPT

• Min. Hose Size / 進氣管尺寸 : 3/8" (9.5mm)

• Air Pressure / 空氣壓力 : 90 psi (6.2bar)



WX-62C



WX-625C



WX-63C



WX-64C-22



WX-64CH / 65CH



WX-65C-4



WX-66C-9 / 66C-10



WS-662



Model	Grinding Wheel	Free Speed	Spindle Thread Size	Angle Head Height	Length	Weight	Air Cons.	Air Inlet	Min. Hose Size	Noise	Packing
型號	砂輪尺寸	無負載轉速	主軸螺紋尺寸	高度	長度	重量	工作耗氣量	進氣口尺寸	進氣管尺寸	噪音值	包裝明細 (CTN)
	inch (mm)	RPM		mm	mm	kg	cfm (l/min)	PT or NPT	inch (mm)	dB (A)	PCS/N.W./G.W./CUFT
WX-62C	2" (50)	15,000	1/4-28 UNF	46	157	0.65	7.1 (200)	1/4"	5/16" (8)	91	20pcs/16.3kg/17.3kg/1.1'
WX-63C-1	3" (75)	15,000	M8 x 1.25	64	180	1.2	14.1 (400)	1/4"	3/8" (9.5)	85	10pcs/14kg/15kg/1.5'
WX-63C	4" (100)	13,500	M8 x 1.25	64	180	1.2	14.1 (400)	1/4"	3/8" (9.5)	85	10pcs/14kg/15kg/1.5'
WX-625C	4" (100)	12,000	M10 x 1.5	75	195	0.9	7.1 (250)	1/4"	3/8" (9.5)	90	10pcs/12kg/13kg/1.5'
WX-64C-22	4" (100)	13,500	M8 x 1.25	77	210	1.8	7.1 (250)	3/8"	3/8" (9.5)	85	10pcs/24kg/25kg/2.4'
WX-64CH	4" (100)	14,000	M8 x 1.25	77	216	2	7.1 (250)	3/8"	3/8" (9.5)	95.2	10pcs/25kg/26kg/2.3'
WX-65CH	5" (125)	12,000	M8 x 1.25	77	216	2.54	14.1 (400)	3/8"	3/8" (9.5)	95.2	10pcs/25.5kg/26.5kg/2.3'
WX-65C-4	5" (125)	12,000	W1/2-16	105	230	2.5	12.7 (360)	3/8"	3/8" (9.5)	95.2	10pcs/25.4kg/26.4kg/2.3'
WX-66C-9	7" (180)	10,000	5/8-11 UNF	107	252	2.98	16.9 (480)	3/8"	1/2" (12.7)	87.7	6pcs/24.3kg/25.3kg/2.3'
WX-66C-10	7" (180)	10,000	W1/2-16	89	252	2.98	16.9 (480)	3/8"	1/2" (12.7)	87.7	6pcs/22.5kg/23.5kg/2.3'
WS-662	4" (100)	11,800	M8 x 1.25	68	210	1.47	9.2 (280)	3/8"	3/8" (9.5)	95.1	15pcs/26kg/27kg/1.4'

• Air Pressure / 空氣壓力 : 90 psi (6.2bar)



WX-624R / 625R



WX-624L / 625L



WX-627R



WX-627L



WX-629L

Model 型號	Throttle Type 開關型式	Grinding Wheel 砂輪片尺寸	Free Speed 無負載轉速	Spindle Thread Size 主軸螺紋尺寸	Angle Head Height 高度	Length 長度	Weight 重量	Air Cons. 工作耗氣量	Noise 噪音值	Packing 包裝明細 (CTN)
		inch (mm)	RPM	3/8 x 24 UNF	mm	mm	kg	cfm (L/min)	dB(A)	PCS/N.W./G.W./CUFT
WX-624R3	Roll	4" (100)	13,600	3/8 x 24 UNF	76	208	1.5	14.1 (400)	92.8	10pcs/20kg/25kg/2.37'
WX-624R8	Roll	4" (100)	13,600	M8 x 1.25P	76	208	1.5	14.1 (400)	92.8	10pcs/20kg/25kg/2.37'
WX-624L3	Lever	4" (100)	13,600	3/8 x 24 UNF	76	246	1.3	14.1 (400)	92.8	10pcs/20kg/25kg/2.37'
WX-624L8	Lever	4" (100)	13,600	M8 x 1.25P	76	246	1.3	14.1 (400)	92.8	10pcs/20kg/25kg/2.37'
WX-625R3	Roll	5" (125)	10,900	3/8 x 24 UNF	76	208	1.6	14.1 (400)	92.6	10pcs/21kg/26kg/2.37'
WX-625R8	Roll	5" (125)	10,900	M8 x 1.25P	76	208	1.6	14.1 (400)	92.6	10pcs/21kg/26kg/2.37'
WX-625L3	Lever	5" (125)	10,900	3/8 x 24 UNF	76	246	1.4	14.1 (400)	91.4	10pcs/21kg/26kg/2.37'
WX-625L8	Lever	5" (125)	10,900	M8 x 1.25P	76	246	1.4	14.1 (400)	91.4	10pcs/21kg/26kg/2.37'
WX-625L14	Lever	5" (125)	10,900	M14 x 2.0P	76	246	1.4	14.1 (400)	91.4	10pcs/21kg/26kg/2.37'
WX-627R5	Roll	7" (180)	7,600	5/8 x 11 UNC	87	253	3.1	16.9 (480)	92.6	6pcs/24kg/27kg/3.13'
WX-627R10	Roll	7" (180)	7,600	M10 x 1.5P	87	253	3.1	16.9 (480)	92.6	6pcs/24kg/27kg/3.13'
WX-627L5	Lever	7" (180)	7,600	5/8 x 11 UNC	87	300	2.9	16.9 (480)	92.6	6pcs/24kg/27kg/3.13'
WX-627L10	Lever	7" (180)	7,600	M10 x 1.5P	87	300	2.9	16.9 (480)	92.6	6pcs/24kg/27kg/3.13'
WX-627L14	Lever	7" (180)	7,600	M14 x 2.0P	87	300	3.0	16.9 (480)	92.6	6pcs/24kg/27kg/3.13'
WX-629L10	Lever	9" (230)	5,900	M10 x 1.5P	115	310	3.3	67 (1876)	98.5	2pcs/10.2kg/11kg/1.19'
WX-629L5	Lever	9" (230)	5,900	5/8 x 11 UNC	115	310	3.3	67 (1876)	98.5	2pcs/10.2kg/11kg/1.19'
WX-629L14	Lever	9" (230)	5,900	M14 x 2.0P	115	310	3.3	67 (1876)	98.5	2pcs/10.2kg/11kg/1.19'

• Air Pressure / 空氣壓力 : 90 psi (6.2bar)

• Air Inlet / 進氣口尺寸 : WX-624.625 : 1/4" PT or NPT, WX-627.629 : 3/8" PT or NPT

• Min. Hose Size / 進氣管尺寸 : WX-624.625 : 3/8" (9.5mm), WX-627.629 : 1/2" (12.7mm)



## Angle Type

彎頭型



WX-634L / 635L / 632L



WX-634R / 635R

Model 型號	Throttle Type 開關型式	Grinding Wheel 砂輪片尺寸	Free Speed 無負載轉速	Spindle Thread Size 主軸螺紋尺寸	Angle Head Height 高度	Length 長度	Weight 重量	Noise 噪音值	Packing 包裝明細 (CTN)
		inch (mm)	RPM		mm	mm	kg	dB (A)	PCS/N.W./G.W./CUFT
WX-634L3	Lever	4" (100)	12,000	3/8 x 24 UNC	86.6	242	1.9	80	12pcs/23kg/24kg/2'
WX-634L10	Lever	4" (100)	12,000	M10 x 1.5	86.6	242	1.9	80	12pcs/23kg/24kg/2'
WX-634R10	Roll	4" (100)	12,000	M10 x 1.5	86.6	229	1.78	80	12pcs/23kg/24kg/2'
WX-632L10	Lever	4-1/2" (114)	12,000	M10 x 1.5	86.6	242	1.9	80	12pcs/23kg/24kg/2'
WX-632L14	Lever	4-1/2" (114)	12,000	M14 x 2.0	86.6	242	1.9	80	12pcs/23kg/24kg/2'
WX-632L5	Lever	4-1/2" (114)	12,000	5/8 x 11UNC	86.6	242	1.9	80	12pcs/23kg/24kg/2'
WX-635L10	Lever	5" (125)	12,000	M10 x 1.5	86.6	242	1.9	80	12pcs/23kg/24kg/2'
WX-635L14	Lever	5" (125)	12,000	M14 x 2.0	86.6	242	1.9	80	12pcs/23kg/24kg/2'
WX-635L5	Lever	5" (125)	12,000	5/8 x 11UNC	86.6	242	1.9	80	12pcs/23kg/24kg/2'
WX-635R10	Roll	5" (125)	12,000	M10 x 1.5	86.6	229	1.78	80	12pcs/23kg/24kg/2'

• Air Cons. / 工作耗氣量 : 6 cfm (170 L/min)

• Air Inlet / 進氣口尺寸 : 1/4" PT or NPT

• Min.HoseSize / 進氣管尺寸 : 3/8" (9.5mm)

• Air Pressure / 空氣壓力 : 90 psi (6.2bar)

## Angle Type

(Governor)彎頭型

One-piece governor design for safety and easy replacement.  
Safety-lock throttle lever prevents accidental start-up and adjustable control.

一體成形的限速器設計，安全性佳、方便更換。  
安全板機防止意外啟動以及有調節控制功能。



WX-674A / 675A(Steel)



WX-674AA / 675AA(Aluminum)

Model 型號	Throttle Type 開關型式	Grinding Wheel 砂輪片尺寸	Free Speed 無負載轉速	Spindle Thread Size 主軸螺紋尺寸	Angle Head Height 高度	Length 長度	Weight 重量	Air Cons. 工作耗氣量	Noise 噪音值	Packing 包裝明細 (CTN)
		inch (mm)	RPM		mm	mm	kg	cfm (L/min)	dB (A)	PCS/N.W./G.W./CUFT
WX-674A	Lever	4" (100)	13,000	3/8-24 or M14*2.0	94	270	2.1	4.2 (119)	87	5PCS/14kgs/14.5kgs/1.1' 10PCS/27kgs/28kgs/2.3'
WX-674AA	Lever	4" (100)	13,000		94	270	1.7	4.2 (119)	87	10PCS/22kgs/23kgs/2.3'
WX-675A	Lever	5" (100)	12,000	3/8-24 or M14*2.0	94	270	2.3	3.5 (99)	85	5PCS/14kgs/14.5kgs/1.1' 10PCS/27kgs/28kgs/2.3'
WX-675AA	Lever	5" (100)	12,000		94	270	1.9	3.5 (99)	85	10PCS/23kgs/24kgs/2.3'

• Air Pressure / 空氣壓力 : 90 psi (6.2bar)

• Air Inlet / 進氣口尺寸 : 3/8" PT or NPT

• Min.HoseSize / 進氣管尺寸 : 3/8" (9.5mm)

## Straight Type

直型



WX-615S / 616S

Model 型號	Throttle Type 開關型式	Max. Grinding Wheel 砂輪尺寸	Free Speed 無負載轉速	Spindle Thread Size 主軸尺寸	Length 長度	Weight 重量	Noise 噪音值	Packing 包裝明細 (CTN)
		mm	RPM		mm	kg	dB (A)	PCS/N.W./G.W./CUFT
WX-615S	Roll	125 x 19 x 12.7	7,000	1/2 x 12	400	2.97	89.4	6pcs/22.1 kg/23.1 kg/2'
WX-615SH	Lever	125 x 19 x 12.7	7,000	1/2 x 12	400	2.97	89.4	6pcs/22.1 kg/23.1 kg/2'
WX-616S	Roll	150 x 25 x 15.8	6,500	5/8 x 11	425	4.14	88.8	6pcs/25.2 kg/27.6 kg/2'
WX-616SH	Lever	150 x 25 x 15.8	6,500	5/8 x 11	425	4.14	88.8	6pcs/27 kg/29.9 kg/2'

• Air Cons. / 工作耗氣量 : 7.1cfm (220 L/min)

• Air Inlet / 進氣口尺寸 : 3/8" PT or NPT

• Min. Hose Size / 進氣管尺寸 : 1/2" (12.7mm)

• Air Pressure / 空氣壓力 : 90 psi (6.2bar)

## Vertical Type

直立型



WX-610G / 610GH



WX-610C / 610CH

Model 型號	Grinding Wheel 砂輪片尺寸	Max. dia Cup Wheel 砂輪尺寸	Free Speed 無負載轉速	Height 高度	Length 長度	Weight 重量	Air Cons. 工作耗氣量	Noise 噪音值	Packing 包裝明細 (CTN)
	inch (mm)	mm	RPM	mm	mm	kg	L/min	dB (A)	PCS/N.W./G.W./CUFT
WX-610GH	230 x 10 x 22.2	N/A	6,000	204	279	5.8	590	92.5	4pcs/25.8 kg/30 kg/2.6'
WX-610G	230 x 10 x 22.2	N/A	4,500	204	279	5.8	440	92.2	4pcs/25.8 kg/30 kg/2.6'
WX-610CH	N/A	150 x 50 x 22.2	6,000	222	279	5.9	590	92.5	4pcs/25.8 kg/30 kg/2.6'
WX-610C	N/A	150 x 50 x 22.2	4,500	222	279	5.9	440	92.2	4pcs/25.8 kg/30 kg/2.6'

• Air Inlet / 進氣口尺寸 : 1/2" PT or NPT

• Min. Hose Size / 進氣管尺寸 : 3/4" (19mm)

• Air Pressure / 空氣壓力 : 90 psi (6.2bar)

# Air Die Grinder



WX-613-2



WX-626-2



WX-626L-1



WX-638A



WX-638AL



WX-650-2



WX-665K



WX-63H-5



WX-62C-2

Model 型號	Throttle Type 開關形式	Collet Capacity 夾頭尺寸	Capacity		Free Speed 無負載轉速	Length 長度	Weight 重量	Air Cons. 工作耗氣量	Noise 噪音值	Packing 包裝明細 (CTN)
			Grinding Wheel 砂輪外徑	Burr Head 錐鋼輪外徑						
		inch or mm	inch (mm)	inch (mm)	RPM	mm	kg	cfm (l/min)	dB (A)	PCS/N.W./G.W./CUFT
WX-613-2	Roll	1/8" or 3	1/2" (13)	3/8" (9.5)	30,000	150	0.4	6 (170)	81.3	20pcs/11.5kg/12.5kg/1.1'
WX-626-2	Roll	1/4" or 6	1" (25)	1/2" (13)	24,000	170	0.6	7.1 (200)	83.5	20pcs/15kg/16kg/1.1'
WX-626L-1	Roll	1/4" or 6	1" (25)	1/2" (13)	24,000	297	0.8	7.1 (200)	83.5	12pcs/12kg/13kg/1.2'
WX-638A	Roll	1/4" or 6	1" (25)	1/2" (13)	24,000	165	0.78	7.8 (220)	92.6	20pcs/15.5kg/16.5kg/1.1'
WX-638AL	Lever	1/4" or 6	1" (25)	1/2" (13)	24,000	172	0.78	7.8 (220)	88.8	20pcs/15.5kg/16.5kg/1.1'
WX-650-2	Roll	1/4" or 6	1-1/4" (32)	7/8" (22)	18,000	180	0.7	7.1 (200)	88.9	20pcs/17kg/18kg/1.1'
WX-665K	Roll	1/4" or 6	1-1/4" (32)	7/8" (22)	16,000	309	1.3	9.9 (280)	95.1	12pcs/22kg/23kg/1.2'
WX-63H-5	Roll	1/4" or 6	1-1/4" (32)	7/8" (22)	18,000	309	1.3	9.9 (280)	90.7	12pcs/18kg/19kg/1.5'
WX-62C-2	Roll	1/4" or 6	1-1/2" (38)	3/8" (9.5)	15,000	157	0.6	7.1 (200)	85	10pcs/8kg/9kg/1.2'

• Air Pressure / 空氣壓力 : 90 psi (6.2bar)

• Air Inlet / 進氣口尺寸 : 1/4" PT or NPT

• Min. Hose Size / 進氣管尺寸 : 5/16" (8mm)



# Air Die Grinder



WX-626-10F (前側排氣)



WX-626X-10F (後排氣)



WX-625DB (前側排氣)



WX-626XB (後排氣)



WX-650X-1F (前側排氣)



WX-650D (前側排氣雙軸承)



WX-650DB (前側排氣)



WX-650XB (後排氣)

Model 型號	Throttle Type 開關形式	Collet Capacity 夾頭尺寸	Capacity		Free Speed 無負載轉速	Length 長度	Weight 重量	Air Cons. 工作耗氣量	Noise 噪音值	Packing 包裝明細 (CTN)
			Grinding Wheel 砂輪外徑	Burr Head 錐鋼輪外徑						
		inch or mm	inch (mm)	inch (mm)	RPM	mm	kg	cfm (l/min)	dB (A)	PCS/N.W./G.W./CUFT
Wx-626-10F	Lever	1/4" or 6	1" (25)	1/2" (13)	24,000	170	0.6	7.7 (220)	85.3	20pcs/17kg/18kg/0.8'
WX-626X-10F	Lever	1/4" or 6	1" (25)	1/2" (13)	24,000	183	0.6	7.7 (220)	80	10pcs/8kg/9kg/1.5'
WX-625DB	Lever	1/4" or 6	1" (25)	1/2" (13)	24,000	190	0.7	7.7 (220)	89.6	10pcs/10.2kg/13.2kg/0.7'
WX-626XB	Lever	1/4" or 6	1" (25)	1/2" (13)	24,000	203	0.5	7.7 (220)	89.4	10pcs/13.4kg/14.4kg/1.55'
WX-650-1F	Lever	1/4" or 6	1-1/4" (32)	7/8" (22)	18,000	187	0.66	7.7 (220)	88.7	20pcs/20kg/21kg/0.8'
WX-650D	Roll	1/4" or 6	1-1/4" (32)	7/8" (22)	18,000	214	0.9	7.4 (200)	87.8	20pcs/20kg/21kg/0.8'
WX-650DB	Lever	1/4" or 6	1-1/4" (32)	7/8" (22)	18,000	210	0.8	7.7 (220)	91.1	10pcs/11.6kg/12.6kg/0.7'
WX-650XB	Lever	1/4" or 6	1-1/4" (32)	7/8" (22)	18,000	214	0.8	7.7 (220)	88.7	10pcs/14.6kg/15.6kg/1.55'

• Air Pressure / 空氣壓力 : 90 psi (6.2bar)

• Air Inlet / 進氣口尺寸 : 1/4" PT or NPT

• Min.HoseSize / 進氣管尺寸 : 5/16" (8mm)

# Air Die Grinder

## Heavy Duty (Governor)

One-piece governor design for safety and easy replacement.  
Compact collect chuck design can reduce run-out. (Erickson type)

一體成形的限速器設計，安全性佳、方便更換。  
精巧的夾頭設計可降低磨損。



WX-6080A (Aluminum)

Model 型號	Collet Capacity 夾頭尺寸	Dia 直徑	Free Speed 無負載轉速	Length 長度	Weight 重量	Air Cons. 工作耗氣量	Noise 噪音值	Packing 包裝明細 (CTN)
	inch or mm	mm	RPM	mm	kg	cfm (l/min)	dB (A)	PCS/N.W./G.W./CUFT
WX-6080A	3, 5, 6, 8, 9, 9.5 3/16", 1/4", 1/8"	41	20,000	220	0.8	3.9 (110)	88.3	20pcs/16kg/16.5kg/1.2'

• Air Pressure / 空氣壓力 : 90 psi (6.2bar)

• Air Inlet / 進氣口尺寸 : 3/8" PT or NPT

• Min.HoseSize / 進氣管尺寸 : 3/8" (9.5mm)

## Composite (Governor)

Tease Trigger  
Compact collect chuck design can reduce  
run-out.(Erickson type)

無段式板機  
精巧的夾頭設計可降低磨損。



WX-6078

Model 型號	Collet Capacity 夾頭尺寸	Dia 直徑	Free Speed 無負載轉速	Length 長度	Weight 重量	Air Cons. 工作耗氣量	Noise 噪音值	Packing 包裝明細 (CTN)
	inch or mm	mm	RPM	mm	kg	cfm (l/min)	dB (A)	PCS/N.W./G.W./CUFT
WX-6078	3, 5, 6, 8, 9, 9.5 3/16", 1/4", 1/8"	42	21,000	198	0.71	3 (88)	81	20pcs/18.4kg/19kg/1.1'

• Air Pressure / 空氣壓力 : 90 psi (6.2bar)

• Air Inlet / 進氣口尺寸 : 1/4" PT or NPT

• Min.HoseSize / 進氣管尺寸 : 3/8" (9.5mm)

## Composite



WX-6079AA



WX-6079A



WX-6079AK

Model 型號	Throttle Type 開關形式	Collet Capacity 夾頭尺寸	Free Speed 無負載轉速	Length 長度	Weight 重量	Air Cons. 工作耗氣量	Noise 噪音值	Packing 包裝明細 (CTN)
		inch or mm	RPM	mm	kg	cfm (l/min)	dB (A)	PCS/N.W./G.W./CUFT
WX-6079AA	Lever	1/4" or 6	20,000	198	0.61	2.4 (85)	76	20pcs/14.9kg/15.9kg/1.2'
WX-6079A	Lever	1/4" or 6	4,500	201	0.89	3 (85)	77	20pcs/18kg/18.8/0.95'

• Air Pressure / 空氣壓力 : 90 psi (6.2bar)

• Air Inlet / 進氣口尺寸 : 1/4" PT or NPT

• Min.HoseSize / 進氣管尺寸 : 5/16" (8mm)

# Air Die Grinder / Sander

Industrial-Composite



Our Particular Gear Set  
曙翔特殊齒輪組



Traditional Gear Set  
傳統齒輪組

VS.

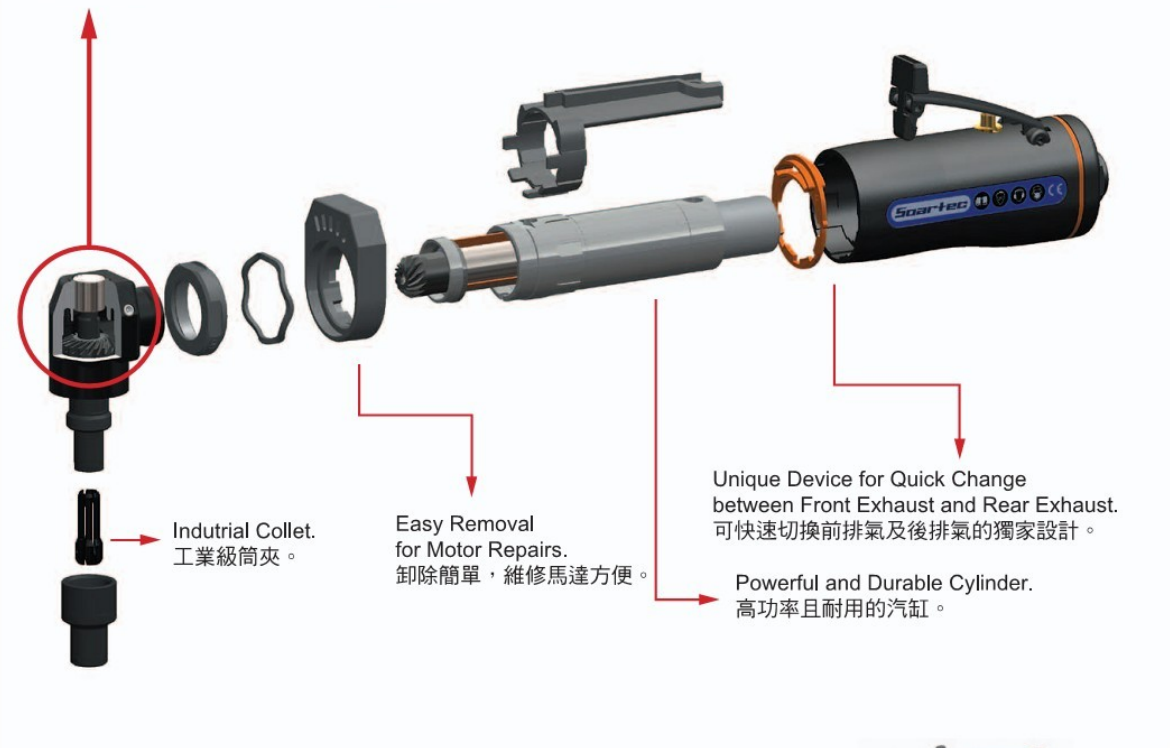

Industrial Collet.  
工業級筒夾。

Easy Removal  
for Motor Repairs.  
卸除簡單，維修馬達方便。

Unique Device for Quick Change  
between Front Exhaust and Rear Exhaust.  
可快速切換前排氣及後排氣的獨家設計。

Powerful and Durable Cylinder.  
高功率且耐用的汽缸。



WZ-1420  
2" Disc Angle Sander



WZ-6130  
Heavy Duty Die Grinder  
(25,000rpm)



WZ-6430 / 6432  
Heavy Duty Angle Die Grinder  
(18,000rpm / 12,000rpm)

Model 型號	Throttle Type 開關形式	Collet Capacity 夾頭尺寸	Free Speed 無負載轉速	Length 長度	Weight 重量	Vibration 震動值	Noise 噪音值	Packing 包裝明細 (CTN)
		inch or mm	RPM	mm	kg	m/s <sup>2</sup>	dB (A)	PCS/N.W./G.W./CUFT
WZ-1420	Lever	-	18,000	151	0.7	3.31	80.0	20pcs/16.2kg/17.2kg/0.82'
WZ-6130	Lever	1/4" or 6	25,000	155	0.5	<2.5	79.1	20pcs/14.7kg/15.7kg/0.75'
WZ-6430	Lever	1/4" or 6	18,000	151	0.7	4.53	79.6	20pcs/18.2kg/19.2kg/0.81'
WZ-6432	Lever	1/4" or 6	12,000	151	0.7	4.60	79.6	20pcs/18.2kg/19.2kg/0.81'

• Air Cons. / 工作耗氣量 : 2.2cfm (62.3 L/min)

• Air Inlet / 進氣口尺寸 : 1/4" PT or NPT

• Air Pressure / 空氣壓力 : 90 psi (6.2bar)



# Air Die Grinder

## Industrial-Steel

### INDUSTRY COLLET CHUCK 工業級夾頭



SPINDLE CONCENTRICITY  
LESS THAN 0.15MM  
BALL BEARING : JAPAN  
CYLINDER MATERIAL : FCD



WX-6082LL



WX-6082SL



WX-6082LXL



WX-6082SXL

Model 型號	Throttle Type 開關形式	Collet Capacity 夾頭尺寸	Free Speed 無負載轉速	Length 長度	Weight 重量	Exhaust 排氣位置	Air Cons. 工作耗氣量	Power 馬力
		inch (mm)	RPM	mm	kg		cfm ( l/min)	HP
WX-6082LL	Lever		20,000	600	2.8	Side	5 (141)	1
WX-6082SL	Roll	1/4", 3/8" (6), (8)	20,000	605	2.8	Side	5 (141)	1
WX-6082LXL	Lever		20,000	1,020	4.7	Side	5 (141)	1
WX-6082SXL	Roll		20,000	1,030	4.7	Side	5 (141)	1



WX-6102L



WX-6102S



WX-6103L



WX-6103S

Model 型號	Throttle Type 開關形式	Collet Capacity 夾頭尺寸	Free Speed 無負載轉速	Length 長度	Weight 重量	Exhaust 排氣位置	Air Cons. 工作耗氣量	Power 馬力
		inch (mm)	RPM	mm	kg		cfm ( l/min)	HP
WX-6102L	Lever		20,000	319	1.3	Side	3.5 (99.1)	0.5
WX-6102S	Roll	1/4", (3), (6)	20,000	330	1.2	Side	3.5 (99.1)	0.5
WX-6103L	Lever		20,000	446	1.5	Side	3.5 (99.1)	0.5
WX-6103S	Roll		20,000	457	1.45	Side	3.5 (99.1)	0.5



WX-6115L



WX-6136L



WX-6139L

Model 型號	Throttle Type 開關形式	Collet Capacity 夾頭尺寸	Free Speed 無負載轉速	Length 長度	Weight 重量	Exhaust 排氣位置	Air Cons. 工作耗氣量	Power 馬力
		inch (mm)	RPM	mm	kg		cfm ( l/min)	HP
WX-6115L	Lever		12,000	263	1.9	Side	5 (141)	1
WX-6136L	Lever	1/4", (6)	16,000	361	1.7	Side	3.5 (99.1)	0.5
WX-6139L	Lever		16,000	488	2	Side	3.5 (99.1)	0.5

• Air Inlet / 進氣口尺寸 : 1/4" PT or NPT

• Min. Hose Size / 進氣管尺寸 : 3/8" (9.5mm)

• Air Pressure / 空氣壓力 : 90 psi (6.2bar)

# Mini Air Die Grinder



WX-605 / 605A



WX-606 / 606A

WX-606 with better quality bearings and blade than WX-605  
606比605多一顆軸承，葉片也較好。

Model 型號	Collet Capacity 筒夾尺寸	Free Speed 無負載轉速	Length 長度	Weight 重量	Air Cons. 工作耗氣量	Noise 噪音值	Packing 包裝明細 (CTN)
	inch / mm	RPM	mm	kg	cfm (l/min)	dB (A)	PC/CTN/N.W./G.W./CUFT
WX-605	3 mm	60,000	135	0.13	5 (142)	84	20pcs/6.5kg/7.5kg/0.95'
WX-605A	1/8"	60,000	135	0.13	5 (142)	84	20pcs/6.5kg/7.5kg/0.95'
WX-606	3 mm	60,000	135	0.135	5.5 (156)	85	20pcs/6.6kg/7.6kg/0.95'
WX-606A	1/8"	60,000	135	0.135	5.5 (156)	85	20pcs/6.6kg/7.6kg/0.95'

- Air Inlet / 進氣口尺寸：1/4" PT or NPT
- Rear exhaust / 後排氣

- Min. Hose Size / 進氣管尺寸：3/16" (5mm)

- Air Pressure / 空氣壓力：90 psi (6.2bar)

## Economy

經濟型



WX-6101



WX-607 / 607A



WX-607R / 607RA

Come with 6 mm-> 3 mm Adaptor  
附 6 mm-> 3 mm 轉換接頭

Model 型號	Collet Capacity 筒夾尺寸	Free Speed 無負載轉速	Length 長度	Weight 重量	Air Cons. 工作耗氣量	Noise 噪音值	Packing 包裝明細 (CTN)
	inch / mm	RPM	mm	kg	cfm (l/min)	dB (A)	PC/CTN/N.W./G.W./CUFT
WX-6101	1/8" or 3 mm	60,000	140	0.24	2.65 (75)	84	20pcs/7kg/8kg/1.2'
WX-607	6 mm	30,000	145	0.27	5.12 (145)	84	20pcs/8kg/9kg/1.2'
WX-607A	1/4"	30,000	145	0.27	5.12 (145)	84	20pcs/8kg/9kg/1.2'
WX-607R	6 mm	30,000	145	0.27	5.12 (145)	84	20pcs/8kg/9kg/1.2'
WX-607RA	1/4"	30,000	145	0.27	5.12 (145)	84	20pcs/8kg/9kg/1.2'

- Air Inlet / 進氣口尺寸：1/4" PT or NPT
- Rear exhaust / 後排氣

- Min. Hose Size / 進氣管尺寸：1/4" (6.35mm)

- Air Pressure / 空氣壓力：90 psi (6.2bar)



WX-6330 / 6330M

Model 型號	Collet Capacity 筒夾尺寸	Free Speed 無負載轉速	Length 長度	Weight 重量	Air Cons. 工作耗氣量	Noise 噪音值	Packing 包裝明細 (CTN)
	inch / mm	RPM	mm	kg	cfm (l/min)	dB (A)	PC/CTN/N.W./G.W./CUFT
WX-6330	1/4"	25,000	123	0.33	6.5 (184)	89.4	20pcs/8kg/11kg/0.6'
WX-6330M	6mm	25,000	123	0.33	6.5 (184)	89.4	20pcs/8kg/11kg/0.6'

- Air Inlet / 進氣口尺寸：1/4" PT or NPT
- Rear exhaust / 後排氣

- Min. Hose Size / 進氣管尺寸：3/8" (9.5mm)

- Air Pressure / 空氣壓力：90 psi (6.2bar)

# Mini Air Die Grinder



WX-630

Tease Trigger  
Compact collect chuck design can reduce run-out.(Erickson type)

無段式板機。  
精巧的夾頭設計可降低磨損。

Model 型號	Collet Capacity 筒夾尺寸	Free Speed 無負載轉速	Length 長度	Weight 重量	Air Cons. 工作耗氣量	Noise 噪音值	Packing 包裝明細 (CTN)
	inch or mm	RPM	mm	kg	cfm (l/min)	dB (A)	PC/CTN/N.W./G.W./CUFT
WX-630	3, 5, 6, 8, 9, 9.5 3/16", 1/4", 1/8"	25,000	156	0.84	3 (88)	85.5	20pcs/20.5kg/21.3kg/0.73'

• Air Inlet / 進氣口尺寸 : 1/4" PT or NPT  
• Front exhaust / 前排氣

• Min. Hose Size / 進氣管尺寸 : 3/8" (9.5mm)

• Air Pressure / 空氣壓力 : 90 psi (6.2bar)

# Air Beveler

BV-100 is ideal for chamfering edges of steel skeleton materials used in various industries such as ship building, bridge and steel frame construction.

Pneumatically driven with easily replaceable carbide tips provide uniform and precise chamfering.

BV-100對於不同行業鋼結構倒角提供了解決方案，如造船、橋樑及建築結構。  
氣體驅動的可簡單更換硬質合金刀片提供了標準及精確的倒角工作。



BV-100

Model 型號	Base Size 底盤尺寸	Chamfering Size 倒角尺寸	Blade 刀片	Free Speed 無負載轉速	Feed Rate 切削速度	Min Working Radius 最小加工半徑	Height 高度	Weight 重量	Air Cons. 工作耗氣量
	mm	mm	pc	RPM	m/min	mm	mm	kg	cfm (l/min)
BV-100	148	R1~R4 or C1~C4(45°)	3	13,000	2~3	R17	160	3.7	35.3 (1,000)

• Air Inlet / 進氣口尺寸 : 3/8" PT or NPT

• Min. Hose Size / 進氣管尺寸 : 3/8" (9.5mm)

• Air Pressure / 空氣壓力 : 90 psi (6.2bar)



# Air Riveter

## Standard

標準款



WX-550 (2Jaws-螺旋牙)  
WX-5503 (3Jaws-螺旋牙)  
3/16" Air-Hydraulic Riveter



WX-551 (2Jaws-螺旋牙)  
WX-5513 (3Jaws-螺旋牙)  
1/4" Air-Hydraulic Riveter

Model 型號	Rivet Capacity 拉釘能力	Max. Rivet Capacity AL. & Steel Stainless 最大拉釘能力		Traction Power 拉力	Tool Stroke 工具行程	Air Cons. 耗氣量	Weight 重量	Working Pressure 操作壓力	Dimensions 尺寸	Noise 噪音值	Packing 包裝明細 (CTN)
	inch (mm)	mm	mm	lb (kg)	mm	CFM	kg	psi	L x W x H (mm)	dB (A)	PCS/N.W./G.W./CUFT
WX-550 WX-5503	3/32"~3/16" (2.4mm~4.8mm)	4.8	4.0	1,950 (885)	14	3.5	1.5	60~100	160 x 77 x 275	82	10pcs/18kg/19 kg/1.85'
WX-551 WX-5513	3/32"~1/4" (2.4mm~6.4mm)	6.4	5.6	3,110 (1,413)	19	4.2	2	80~100	180 x 90 x 320	86	6pcs/16kg/17 kg/1.9'

## Long Life Design

長壽款



WX-5593(3 Jaws only-平行牙)  
3/16" Air-Hydraulic Riveter



WX-5603(3 Jaws only-平行牙)  
1/4" Air-Hydraulic Riveter

Model 型號	Rivet Capacity 拉釘能力	Max. Rivet Capacity AL. & Steel Stainless 最大拉釘能力		Traction Power 拉力	Tool Stroke 工具行程	Air Cons. 耗氣量	Weight 重量	Working Pressure 操作壓力	Dimensions 尺寸	Noise 噪音值	Packing 包裝明細 (CTN)
	inch (mm)	mm	mm	lb (kg)	mm	CFM	kg	psi	L x W x H (mm)	dB (A)	PCS/N.W./G.W./CUFT
WX-5593	1/8"~ 3/16" (3.2-4.0-4.8mm)	4.8	4.0	1,960 (890)	14	1.8	1.5	71~85	254 x 78 x 276	81	10pcs/20.3kg/21.3 kg/2.58'
WX-5603	5/32"~1/4" (4.0-4.8-6.4mm)	6.4	4.8	3,130 (1,420)	16	2.4	2	71~85	274 x 90 x 306	81	8pcs/19kg/20kg/2.28'

## Industrial W/Vacuum

工業級



WX-5553(3 Jaws only-平行牙)  
5/32" Industrial Air-Hydraulic Riveter



WX-5563(3 Jaws only-平行牙)  
3/16" Industrial Air-Hydraulic Riveter



WX-5573(3 Jaws only-平行牙)  
1/4" Industrial Air-Hydraulic Riveter



WX-5583(3 Jaws only-平行牙)  
1/4" H.D. Industrial Air-Hydraulic Riveter

Model 型號	Rivet Capacity 拉釘能力	Max. Rivet Capacity AL. & Steel Stainless 最大拉釘能力		Traction Power 拉力	Tool Stroke 工具行程	Air Cons. 耗氣量	Weight 重量	Working Pressure 操作壓力	Dimensions 尺寸	Noise 噪音值	Packing 包裝明細 (CTN)
	inch (mm)	mm	mm	lb (kg)	mm	liter / per shoot	kg	psi	L x W x H (mm)	dB (A)	PCS/N.W./G.W./CUFT
WX-5553	1/8"~ 5/32" (3.2-4.0mm)	4.0	3.2	1,346 (612)	14	1.2	1.56	71~100	287 x 107 x 264	>75	3pcs/4.68kg/5.68kg/2.1'
WX-5563	1/8"~3/16" (3.2-4.0-4.8mm)	4.8	4.0	2,097 (953)	17	2.1	1.78	71~100	306 x 123 x 289	>75	3pcs/5.34kg/6.34kg/2.1'
WX-5573	5/32"~ 1/4" (4.0-4.8-6.4mm)	6.4	4.8	2,895 (1,316)	26	4.3	2.07	71~100	324 x 137 x 321	>75	3pcs/6.21kg/7.21kg/2.1'
WX-5583	5/32"~ 1/4" (4.0-4.8-6.4mm)	6.4	6.4	4,194 (1,906)	17	4.6	2.11	71~100	324 x 137 x 321	>75	3pcs/6.33kg/7.33kg/2.1'

● Air Inlet / 進氣口尺寸 : 1/4" PT or NPT

● Min. Hose Size / 進氣管尺寸 : 3/8" (9.5mm)

● Blind Rivets / 鉚釘材質 : Aluminum / Steel / Stainless

# Air Spray Gun



WX-801PT  
HP 高壓槍



WX-801HT  
HVLP 高流量低壓槍



WX-802PT  
HP 高壓槍



WX-803PT  
HP 高壓槍



WX-803HT  
HVLP 高流量低壓槍



WX-804PS  
HP 高壓槍



WX-804PB  
HP 高壓槍



WX-805HT  
HVLP高流量低壓槍



WX-805XT  
XRP 面漆用低壓環保槍



WX-806HT  
HVLP 高流量低壓槍



WX-806HB  
HVLP高流量低壓槍



WX-807PS  
HP高壓槍



WX-807PB  
HP高壓槍

Model 型號	Nozzle 噴嘴尺寸	Air Cons 工作耗氣量	Cup Capacity 漆杯容量	Fluid Inlet Size 入漆口規格	Working Pressure 工作壓力	Weight 重量	Packing 包裝明細 (CTN)
	mm	l/min	c.c.		psi	g	PCS/N.W./G.W./CUFT
WX-801PT	1.3/1.4/1.5/1.7/2.0/2.5	190	600	M16*1.5P	30~45	620	10pcs/10.5kg/11.5kg/1.7'
WX-801HT	1.3/1.4/1.5/1.7/2.0	250	600	M16*1.5P	15~28	620	10pcs/10.5kg/11.5kg/1.7'
WX-802PT	0.5/0.8/1.0/1.2	80-90	125	M14*1.0P	30~45	280	20pcs/11kg/12kg/1.4'
WX-803PT	1.0/1.2/1.3/1.4/1.5/1.6/1.8/2.0/2.5	210	600	M16*1.5P	30~45	514	10pcs/9.5kg/10.5kg/1.7'
WX-803HT	1.0/1.2/1.3/1.4/1.5/1.6/1.8/2.0/2.5	270	600	M16*1.5P	15~28	514	10pcs/9.5kg/10.5kg/1.7'
WX-804PS	0.8/1.1/1.4/1.8/2.0/2.5	190	250 or 400	1/4" NPS	30~45	476	10pcs/9.6kg/10.6kg/1.7'
WX-804PB	1.1/1.4/1.8/2.0/2.5	190	700 or 1,000	1/4"NPS	30~45	486	10pcs/10kg/11kg/1.7'
WX-805HT	1.3/1.4/1.7/1.8/2.0/2.5	300	600	M16*1.5P	15~28	450	10pcs/9.3kg/1.3kg/1.7'
WX-805XT	1.3/1.4/1.7/1.8/2.0/2.5	280	600	M16*1.5P	15~28	450	10pcs/9.3kg/10.3kg/1.7'
WX-806HT	1.3/1.4/1.5/1.7/2.0/2.5/3/3.5	250-270	600	M16*1.5P	15~28	620	10pcs/10.5kg/11.5kg/1.7'
WX-806HB	1.3/1.4/1.5/1.7/2.0/2.5	250-270	1,000	3/8"NPS	15~28	630	10pcs/14kg/15kg/1.7'
WX-807PS	0.8/1.0/1.3/1.5/1.8/2.0/2.5	200-230	250 or 400	1/4"NPS	30~45	410	10pcs/8kg/9kg/1.7'
WX-807PB	0.8/1.0/1.3/1.5/1.8/2.0/2.5	200-230	700 or 1,000	1/4" or 3/8" NPS	30~45	410	10pcs/9.5kg/10.5kg/1.7'

● Air Inlet / 進氣口尺寸 : 1/4" NPS

P : HP 高壓槍 / H : HVLP高流量低壓槍 / X : XRP面漆用低壓環保槍

T : Top Cup上杯 / B : Botton Cup下杯 / S : Side Cup側杯

HVLP = High Volume Low Pressure

HP= High Pressure

XRP = Extra Reduce Pressure

# Air Lubricator

## Air Lubricator For Grease Japanese Type Low Noise



GL-MT20



GL-MT20A



GL-MN200

Model 型號	Capacity 容量	Max. pressure that pump could with stand 泵浦可承壓力	Shrink rate 壓縮比	Volume output 出口油量	Hose 油管規格	Weight 重量
	L	kg		L/min		kg
GL-MT20	20 L	7~9	1/45~1/50	2	1/4" x 2W x 3M	21
GL-MT20A	20 L	7~9	1/45~1/50	2	1/4" x 2W x 3M	20
GL-MN200	置於 50 加侖桶上 Filled in 50 gallons tank	7~9	1/45~1/50	2	1/4" x 2W x 6M	13+12

## Air Lubricator For Oil



OL-N200



OL-N200A

Model 型號	Capacity 容量	Max. pressure that pump could with stand 泵浦可承壓力	Shrink rate 壓縮比	Volume output 出口油量	Hose 油管規格	Weight 重量
	L	kg		c.c. or L/min		kg
OL-N200	置於 50 加侖桶上 Filled in 50 gallons tank	6~13	1/45~1/50	1150 c.c./min	1/4" x 2W x 6M	10+12
OL-N200A	置於 50 加侖桶上 Filled in 50 gallons tank	2~9	1/1	26 L/min	1/2" x 2B x 5M	8.5



# Air Lubricator

## Air Lubricator For Grease American Type



GL-RT20



GL-RD30



GL-RD8



GL-RD30A



GL-RN200



GL-RN200A

Model 型號	Capacity 容量	Max. pressure that pump could with stand 泵浦可承壓力	Shrink rate 壓縮比	Volume output 出口油量	Hose 油管規格	Weight 重量
	L	kg		c.c. or L/min		kg
GL-RT20	20 L	6~13	1/45~1/50	1150 c.c/min	1/4" x 2W x 3M	14.7
GL-RD30	30 L	6~13	1/45~1/50	1150 c.c/min	1/4" x 2W x 3M	13
GL-RD8	8 L	6~13	1/45~1/50	1150 c.c/min	1/4" x 2W x 2M	9
GL-RD30A	30 L	6~13	1/45~1/50	1150 c.c/min	1/4" x 2W x 3M	15
GL-MN200	置於5加侖桶上 Filled in 5 gallons tank	7~9	1/45~1/50	2 L/min	1/4" x 2W x 6M	13+12
GL-MN200A	置於5加侖桶上 Filled in 5 gallons tank	6~13	1/45~1/50	1150 c.c/min	1/4" x 2W x 3M	10.7

## Accessories



3GLM54100  
Standard Grease Gun  
標準型氣動黃油鎗



3GLR54100  
Deluxe Grease Gun  
豪華型氣動黃油鎗



OL-G1  
Setting for Oil Gun  
微電腦電子式定量機油鎗



797010000  
Micro Computer Digital Flow Meter  
電子錶 (適用機油鎗)

# Torque Wrench



**LS**

**Torque Wrench**  
Adjustable Torque



Model 型號	Square Size 前軸尺寸	Range 扭力範圍	Length 長度	Weight 重量	Packing 滿箱數
	inch	Nm	mm	kg	pc
TW-LS25N	1/4"	5~25	280	0.60	20
TW-LS110N	3/8"	19~110	365	0.85	20
TW-LS210N	1/2"	42~210	470	1.20	12
TW-LS350N	1/2"	70~350	600	2.50	6
TW-LS450N	3/4"	65~450	860	3.75	4
TW-LS980N	1"	140~980	1210	7.00	2

Model 型號	Square Size 前軸尺寸	Range 扭力範圍	Length 長度	Weight 重量	Packing 滿箱數
	inch	in.lb or ft.lb	mm	kg	pc
TW-LS200	1/4"	20~200 in.lb	280	0.60	20
TW-LS80F	3/8"	5~80 ft.lb	365	0.85	20
TW-LS150F	1/2"	10~150 ft.lb	470	1.20	12
TW-LS250F	1/2"	50~250 ft.lb	600	2.50	6
TW-LS300F	3/4"	50~300 ft.lb	860	3.75	4
TW-LS600F	3/4"	100~600 ft.lb	1020	6.25	2



Model 型號	Square Size 前軸尺寸	Range 扭力範圍	Length 長度	Weight 重量	Packing 滿箱數
	inch	Nm	mm	kg	pc
TW-LD25N	1/4"	5~25	330	0.80	20
TW-LD110N	3/8"	10~110	420	1.10	20
TW-LD210N	1/2"	40~210	520	1.50	12
TW-LD350N	1/2"	70~350	620	3.00	6

**LD**

**Torque Wrench**  
Adjustable Torque



# Spring Balancer



## SB-A Series

Economic application.  
Convenient force adjustment by rotary adjustment cap.

經濟實用。  
使用旋轉式調整蓋，調整拉力方便不費事。

Model 型號	Capacity 荷重	Weight 淨重	Travel 揚長	Rope Option 繩索	Rope Dia 繩索線徑	Packing 滿箱數
	kg	kg	m		mm	pc
SB-A1.5	0.6~1.5	0.52	1.4	Nylon/Cable	2.5	40
SB-A2	1.0~2.0	0.53	1.4	Nylon/Cable	2.5	40
SB-A3	1.5~3.0	0.76	1.5	Cable	3.2	30
SB-A5	3.0~5.0	0.81	1.5	Cable	3.2	30



SB-C1.5



SB-C3-C15



SB-C22-C70

## SB-C Series

It's suspending equipment meeting the ergonomic requirement.  
It prevents the tool from colliding and falling.

符合人體工學的工具懸吊設備。  
它可以保護工具免於碰撞及掉落。

Model 型號	Capacity 荷重	Weight 淨重	Travel 揚長	Rope Option 繩索	Rope Dia 繩索線徑	Packing 滿箱數
	kg	kg	m		mm	pc
SB-C1.5	0.5~1.5	0.73	1.3	Cable	2	20
SB-C3	1.5~3.0	1.73	1.3	Cable	3.2	10
SB-C5	3.0~5.0	1.82	1.3	Cable	3.2	10
SB-C9	5.0~9.0	3.59	1.3	Cable	4	4
SB-C15	9.5~15.0	3.61	1.3	Cable	4	4
SB-C22	15.0~22.0	7.7	1.5	Cable	4.8	3
SB-C30	22.0~30.0	8.3	1.5	Cable	4.8	3
SB-C40	30.0~40.0	9.7	1.5	Cable	4.8	1
SB-C50	40.0~50.0	10.1	1.5	Cable	4.8	1
SB-C60	50.0~60.0	11.1	1.5	Cable	4.8	1
SB-C70	60.0~70.0	11.4	1.5	Cable	4.8	1



SB-L



SB-K

## SB-L / SB-K Series

Integrating air hose & support cable keep work area clean.  
It is easy to adjust tension by using handle Hex key.

風管吊車系列使用於氣動工具，結合風管捲筒及彈簧吊車，  
讓生產線上整齊不零亂，提昇工作效率。

Model 型號	Capacity 荷重	Weight 淨重	Travel 揚長	Hose Material 風管材質	Rope Dia 繩索線徑	Packing 滿箱數
	kg	kg	m		mm	pc
SB-L1.5	0.5~1.5	2.2	1.5	PU Braided	8 x 12	6
SB-L2.5	1.5~2.5	2.2	1.3	PU Braided	8 x 12	6
SB-L3.5	2.5~3.5	2.4	1.3	PU Braided	8 x 12	6
SB-L5	3.5~5.0	2.4	1.3	PU Braided	8 x 12	6
SB-L6.5	5.0~6.5	2.5	1.3	PU Braided	8 x 12	6
SB-K1.5	0.5~1.5	1.8	1.4	Polyurethane	6.5 x 10.0	6
SB-K3	1.5~3.0	1.9	1.4	Polyurethane	6.5 x 10.0	6
SB-K5	3.0~5.0	2	1.4	Polyurethane	6.5 x 10.0	6



# One Touch Coupler

## 單手操作快速接頭

產品圖片	型號	品名	規格
	SM系列	Item No.	Description (Male)
	7921B2011	SM20 - One Touch	1/4" PT外牙
	7921B3011	SM30 - One Touch	3/8" PT外牙
	7921B4011	SM40 - One Touch	1/2" PT外牙

產品圖片	型號	品名	規格
	SH系列	Item No.	Description (inner Dia.)
	7921B2021	SH20 - One Touch	5/16" Hose
	7921B3021	SH30 - One Touch	3/8" Hose
	7921B4021	SH40 - One Touch	1/2" Hose

產品圖片	型號	品名	規格
	SF系列	Item No.	Description (Female)
	7921B2001	SF20 - One Touch	1/4" PT內牙
	7921B3001	SF30 - One Touch	3/8" PT內牙
	7921B4001	SF40 - One Touch	1/2" PT內牙

產品圖片	型號	品名	規格
	SP系列	Item No.	Description
	7921B2031	SP20 - One Touch	PU 5x8mm
	7921B3031	SP30 - One Touch	PU 6.5x10mm
	7921B4031	SP40 - One Touch	PU 8x12mm

# Nipple

## 固定接頭











產品圖片	型號	品名	規格
	PH系列	Item No.	Description (inner Dia.)
	792121021	PH10	1/8" Hose
	792122021	PH20	5/16" Hose
	792123021	PH30	3/8" Hose
792124021	PH40	1/2" Hose	

產品圖片	型號	品名	規格
	PF系列	Item No.	Description (Female)
	792121001	PF10	1/8" PT內牙
	792122001	PF20	1/4" PT內牙
	792123001	PF30	3/8" PT內牙
792124001	PF40	1/2" PT內牙	





產品圖片	型號	品名	規格
	PP系列	Item No.	Description
	792121031	PP10	PU 4x6mm
	792122031	PP20	PU 5x8mm
	792123031	PP30	PU 6.5x10mm
792124031	PP40	PU 8x12mm	

產品圖片	型號	品名	規格
	PM系列	Item No.	Description (Male)
	792121011	PM10	1/8" PT外牙
	792122011	PM20	1/4" PT外牙
	792123011	PM30	3/8" PT外牙
792124011	PM40	1/2" PT外牙	

Material(材質) : Steel(鋼鐵)

Photo 產品圖片	Item No. (Old No.) 型號	Size mm (inch) 尺寸	Shape Hole 型式	Weight (g) 重量	Thickness (mm) 厚度	Thread 螺牙	Surface 表面	Memo 備註
	798012601 (310609102)	1-1/4"	None	9g		1/4"-20 Female	Vinyl	
	798012602 (310609102)	1-1/4"	None	8g		1/4"-20 Female	Velcro	
	798020202	50 (2")	None	17g	10mm	5/16"-24 Male	Velcro	
	798020601	50 (2")	None	25g		內1/4"-20	Vinyl	
	798020602	50 (2")	None	25g		內1/4"-20	Velcro	
	798030002	75 (3")	None	25g	14mm	M6 Male	Velcro	
	798030202	75 (3")	3 Hole	30g	12mm	5/16"-24 Male	Velcro	
	798030211	75 (3")	None	25g	10.5mm	5/16"-24 Male	Vinyl	
	798030212	75 (3")	None	25g	12mm	5/16"-24 Male	Velcro	
	798030221 (310510301)	75 (3")	None	80g	13mm	5/16"-24 Male	Vinyl	
	798030222 (310510302)	75 (3")	None	80g	14mm	5/16"-24 Male	Velcro	

# Accessories

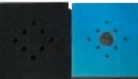





Photo 產品圖片	Item No. (Old No.) 型號	Size mm (inch) 尺寸	Shape Hole 型式	Weight (g) 重量	Thickness (mm) 厚度	Thread 螺牙	Surface 表面	Memo 備註
	798030502	75 (3")	None	25g	12mm	M6*1.0 Female	Velcro	
	798030602	75 (3")	None	25g	12mm	1/4"-20 Female	Velcro	
	798034201 (310510351)	3-1/2"	None	80g	13mm	5/16"-24 Male	Vinyl	
	798034202 (310510352)	3-1/2"	None	80g	14mm	5/16"-24 Male	Velcro	
	798050201 (310510501)	125 (5")	None	100g	9mm	5/16"-24 Male	Vinyl	
	798050202 (310510502)	125 (5")	None	100g	10mm	5/16"-24 Male	Velcro	
	798050211	125 (5")	None	100g	9mm	5/16"-24 Male	Vinyl	Soft
	798050222	125 (5")	6 Hole	100g	13.5mm	5/16"-24 Male	Velcro	Soft
	798050231 (310510511)	125 (5")	6 Hole	100g	9.5mm	5/16"-24 Male	Vinyl	
	798050232 (310510512)	125 (5")	6 Hole	100g	10.5mm	5/16"-24 Male	Velcro	
	798050241 (310510521)	125 (5")	None	100g	12mm	5/16"-24 Male	Vinyl	
	798050242 (310510522)	125 (5")	None	100g	13mm	5/16"-24 Male	Velcro	







# Accessories

Photo 產品圖片	Item No. (Old No.) 型號	Size mm (inch) 尺寸	Shape Hole 型式	Weight (g) 重量	Thickness (mm) 厚度	Thread 螺牙	Surface 表面	Memo 備註
	798050252 (310510532)	125 (5")	5 Hole	100g	10mm	5/16"-24 Male	Velcro	
	798050262	125 (5")	44 Hole	100g	9.5mm	5/16"-24 Male	Velcro	
	798050262 (310510601)	150 (6")	None	130g	8.5mm	5/16"-24 Male	Vinyl	
	798060202 (310510602)	150 (6")	None	130g	9.5mm	5/16"-24 Male	Velcro	
	798060211 (310510611)	150 (6")	6 Hole	130g	8.5mm	5/16"-24 Male	Vinyl	
	798060212 (310510612)	150 (6")	6 Hole	130g	9.5mm	5/16"-24 Male	Velcro	
	798060222 (310510622)	150 (6")	7 Hole	130g	12mm	5/16"-24 Male	Velcro	
	798060232 (310510632)	150 (6")	15 Hole	130g	12mm	5/16"-24 Male	Velcro	
	798060242	150 (6")	65 Hole	130g	9.5mm	5/16"-24 Male	Velcro	
	798070801	178 (7")	None	190g	32.8mm	5/8"-11 Female	Vinyl	
	798070802	178 (7")	None	190g	32.8mm	5/8"-11 Female	Velcro	
	798070812	178 (7")	None	190g	32.8mm	M14x2 Female	Velcro	

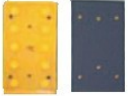

# Accessories

Photo 產品圖片	Item No. (Old No.) 型號	Size mm (inch) 尺寸	Shape Hole 型式	Weight (g) 重量	Thickness (mm) 厚度	Thread 螺牙	Surface 表面	Memo 備註
	310209001	100 x 110mm	None				Vinyl	WS-102J Hard
	310209002	100 x 110mm	None				Velcro	WS-102J Hard
	310209003	100 x 110mm	None				Vinyl	WS-102J Soft
	310209004	100 x 110mm	None				Velcro	WS-102J Soft
	310209012	100 x 110mm	Vac				Velcro	WS-102JP Soft
	310209021	100 x 110mm	None				Vinyl	WS-102JC Soft
	310209031	100 x 110mm	None				Vinyl	WS-102JC Hard
	310209032	100 x 110mm	None				Velcro	WS-102JC Hard
	310209033	100 x 110mm	None				Velcro	WS-102JC Soft
	310209501	125 x 95mm	None				Vinyl	WS-102T Hard
	310209502	125 x 95mm	None				Velcro	WS-102T Hard
	310209512	125 x 95mm	Vac				Velcro	WS-102TP Hard

# Accessories

Photo 產品圖片	Item No. (Old No.) 型號	Size mm (inch) 尺寸	Shape Hole 型式	Weight (g) 重量	Thickness (mm) 厚度	Thread 螺牙	Surface 表面	Memo 備註
	310809100	3-2/3" x 7" (92 x 173mm)	None		10mm		Vinyl	
	310809101	3-2/3" x 7" (92 x 173mm)	10 Hole		10mm		Vinyl	
	310809102	3-2/3" x 7" (92 x 173mm)	None		11mm		Velcro	
	310809103	3-2/3" x 7" (92 x 173mm)	10 Hole		11mm		Velcro	
	313320601	3" x 4"	4 Hole		9mm		Vinyl	
	313320602	3" x 4"	4 Hole		10mm		Velcro	

## Conversion Pad (Hook side to Loop side)

	798105012	5"	50 Hole		2.5mm		Velcro	
	798106012	6"	50 Hole		4mm		Velcro	

## Backing Pad

Photo 產品圖片	Item No. 型號	Size mm (inch) 尺寸	Specification 規格	Color 顏色	Thread 螺牙	Memo 備註
	798200020	50 (2")		Black	Roloc Type	
	798200030	75 (3")		Black	Roloc Type	



## Surface Sanding Disc

Photo 產品圖片	Item No. 型號	Size mm (inch) 尺寸	Specification 規格	Color 顏色	Thread 螺牙	Memo 備註
	798210820	50 (2")	80 grit		Roloc Type	
	798210830	75 (3")	80 grit		Roloc Type	

## Surface Conditioning Disc

	798220120	50 (2")	Coarse	Brown	Roloc Type	
	798220130	75 (3")	Coarse	Brown	Roloc Type	
	798220220	50 (2")	Medium	Red	Roloc Type	
	798220230	75 (3")	Medium	Red	Roloc Type	
	798220320	50 (2")	Fine	Blue	Roloc Type	
	798220330	75 (3")	Fine	Blue	Roloc Type	
	798220420	50 (2")	Super Fine	Gray	Roloc Type	
	798220430	75 (3")	Super Fine	Gray	Roloc Type	

## Non-Woven

	7A03020D0	50 (2")	Coarse #320	Red Brown	Hook	
	7A03030D0	75 (3")	Coarse #320	Red Brown	Hook	
	7A0305000	125 (5")	Coarse #320	Red Brown	Hook	
	7A03060D0	150 (6")	Coarse #320	Red Brown	Hook	
	7A03020H0	50 (2")	Medium #600	Green	Hook	
	7A03030H0	75 (3")	Medium #600	Green	Hook	
	7A03050H0	125 (5")	Medium #600	Green	Hook	
	7A03060H0	150 (6")	Medium #600	Green	Hook	
	7A03020J0	50 (2")	Fine #800	Gray	Hook	
	7A03030J0	75 (3")	Fine #800	Gray	Hook	
	7A03050J0	125 (5")	Fine #800	Gray	Hook	
	7A03060J0	150 (6")	Fine #800	Gray	Hook	
	7A03020K0	50 (2")	Very Fine #1,000	White	Hook	
	7A03030K0	75 (3")	Very Fine #1,000	White	Hook	
	7A03050K0	125 (5")	Very Fine #1,000	White	Hook	
	7A03060K0	150 (6")	Very Fine #1,000	White	Hook	

## Repair Tools

### 維修工具



Bearing Puller 軸承拔卸器  
(30~50mm外徑用)  
No. 799002010



Motor Nut Socket 拆卸套筒組  
No. 310109002



Shaft Puller 中心軸拆卸工具組  
No. 310110000

## Spare Parts for WS-103/WS-103

### 配件

Photo 產品圖片	Item No. 型號	Size (mm) 尺寸	Specification 規格	Color 顏色	Memo 備註
	310320080	60 x 260	#80	Red Brown	MOQ / 最低量 : 100pcs
	310320100	60 x 260	#100	Red Brown	MOQ / 最低量 : 100pcs
	310320120	60 x 260	#120	Red Brown	MOQ / 最低量 : 100pcs
	310320150	60 x 260	#150	Red Brown	MOQ / 最低量 : 100pcs
	310320180	60 x 260	#180	Red Brown	
	310320240	60 x 260	#240	Red Brown	MOQ / 最低量 : 100pcs
	310320600	60 x 260	#600	Red Brown	MOQ / 最低量 : 100pcs
	7A0310040	60 x 260	Coarse	Brown	
	7A0310070	60 x 260	Medium	Red	
	7A0310080	60 x 260	Fine	Green	
	7A0310090	60 x 260	Very Fine	Blue	
	7A03100D0	60 x 260	Super Fine	Gray	



Sponge Wheel 驅動輪

Size / 尺寸 : D50 x B60 x d8  
No. 310302200 Hard 硬  
No. 310302201 Medium 中  
No. 310302202 Soft 軟



Rubber Wheel 橡膠輪

Size / 尺寸 : D50 x B60 x d8  
No. 310302203

## Others

### 其他



Foam Polishing Pad 泡綿 PAD

Spec. / 規格 : #70 Grit  
No. 310510130 3" / 3吋  
No. 310510150 5" / 5吋  
No. 310510160 6" / 6吋



Synthetic Wool Buff 羊毛輪

No. 310511030 3" / 3吋  
No. 310511050 5" / 5吋

# Conversion Factors

## 單位換算表

FLOW 流量			
cfm	l/min	l/sec	m <sup>3</sup> /min
1	28.3168	0.4719	0.0283
0.0353	1	0.0167	0.001
2.1189	60	1	0.06
35.3147	1000	16.6667	1

cfm >> l/min : 10 cfm x 28.3168 = 283.168 l/min  
l/min >> cfm : 15 l/min x 0.0353 = 0.5295 cfm

PRESSURE 壓力		
kg/cm <sup>2</sup>	psi (lb/in <sup>2</sup> )	bar
1	14.2233	0.9807
0.0703	1	0.069
1.0197	14.5032	1

psi >> kg/cm<sup>2</sup> : 90 psi x 0.0102 = 6.327 kg/cm<sup>2</sup>  
bar >> psi : 6 bar x 14.5032 = 87.0192 psi

LENGTH 長度			
mm	m	inch	foot
1	0.001	0.0394	0.0033
1000	1	39.3701	3.2808
25.4	0.0254	1	0.0833
304.8	0.3048	12	1

mm >> inch : 10 mm x 0.0394 = 0.394 inch  
m >> feet : 15 m x 3.2808 = 49.212 feet

TORQUE 扭力		
N-m	kg-m	ft-lb
1	0.102	0.7375
9.807	1	7.233
1.3559	0.1383	1

N-m >> ft-lb : 10 N-m x 0.7375 = 7.375 ft-lb  
ft-lb >> kg-m : 15 ft-lb x 0.1383 = 15.9045 kg-m

WEIGHT or FORCE 重量或力		
kg	lb	N
1	2.2046	9.807
0.4536	1	4.4484
0.102	0.2248	1

kg >> lb : 15 kg x 2.2046 = 33.069 lb  
N >> kg : 10 N x 0.1020 = 1.02 kg

POWER 動力		
kW	ps (metric)	HP
1	1.3596	1.341
0.7355	1	0.9863
0.7457	1.0139	1

kW >> ps : 10 kW x 1.3596 = 13.596 ps  
HP >> kW : 15 HP x 0.7457 = 11.1855 kW

## Guideline values for tightening torques

### 螺栓之適當鎖緊扭力值參考

Bolt Size	Socket Size	Bolt Grade									DIN 267
		3.6	4.6	4.8	5.6	5.8	6.8	8.8	10.9	12.9	
M4	7	0.85	1.1	1.4	1.5	1.9	2.3	2.9	4.1	4.9	
M5	9	1.7	2.2	2.8	3	3.7	4.5	6	8.5	10	
M6	10	2.9	3.9	4.8	5.1	6.4	7.7	10	14	17	
M8	13	7	9.3	12	12	16	19	25	35	41	
M10	17	14	19	23	25	31	37	49	69	83	
M12	19	24	32	40	43	54	65	86	120	145	
M14	22	39	51	64	68	86	105	135	190	230	
M16	24	59	79	98	105	130	155	210	295	355	
M18	27	81	110	135	145	180	215	290	405	485	
M20	30	115	155	190	205	255	305	410	580	690	
M22	32	155	205	260	275	345	415	550	780	930	
M24	36	265	200	330	350	440	530	710	1,000	1,200	
M27	41	295	390	490	520	650	780	1,050	1,500	1,800	
M30	46	395	530	660	710	880	1050	1,450	2,000	2,400	

- Torque Unit : Nm
- Recommended max. tightening torque for untreated oil-smeared screws.
- These torque values are only guide lines and are calculated with friction factor 0.125.
- 扭力單位 : Nm
- 上表之表面狀態為無處理或磷酸鹽處理，潤滑狀態為油潤滑的螺栓最大鎖緊扭力建議值。
- 扭力值僅供參考，計算依據之摩擦係數為 0.125。



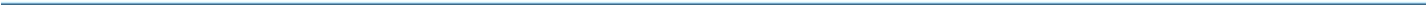

---

**暉翔工業有限公司**  
**Soartec Industrial Corp.**

41349台中市霧峰區民生路288-6號  
No.288-6, Minsheng Rd., Wufeng Dist., Taichung 41349, Taiwan.  
Tel: +886-4-23330499  
Fax: +886-4-23306617  
Email: [soartec@soartec.com.tw](mailto:soartec@soartec.com.tw)  
[soartec.com@msa.hinet.net](mailto:soartec.com@msa.hinet.net)



**[www.soartec.com.tw](http://www.soartec.com.tw)**