



手動油壓床

MANUAL HYDRAULIC PRESS



可伸縮延長心軸
Arbor can be shrank
and extended

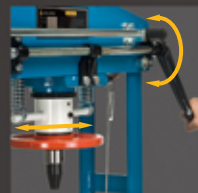

壓床頭部可左右移動
The head of Hydraulic
Press can move left
or right



工作台可調整高度，
方便工件放置
The height of working
table can be adjusted

HP151 | 15 TON 手動油壓床

MANUAL HYDRAULIC PRESS

特點

- (1) 手動操作，無需電力。
- (2) 工作台可依工作物件的大小，上、下自由調整工作距離。
- (3) 專業型手動油壓床，為機械、模具、汽車維修時，不可或缺的利器。
- (4) 油壓主體可依工作物件的大小，上、下、左、右，自由調整工作距離。
- (5) 適用於各種機件彎曲變形、校正、整塑，或軸承、齒輪軸心壓入或逼出等功用。

Feature

- (1) Can be operated manually. No electricity is needed.
- (2) Work table can freely adjust working distance (up-down) as per the size of work piece.
- (3) Professional manual hydraulic press: Unnecessary & efficient instrument for repairing and maintaining machinery, mold and automobile.
- (4) Hydraulic main body can adjust freely work distance (up/down/left/right) as per size of work piece.
- (5) Suitable to be applied for such functions as bending, deforming, rectifying, modeling or for bearing and gear shaft arbor getting pressed in or enforcing out.

尺寸圖 Dimension

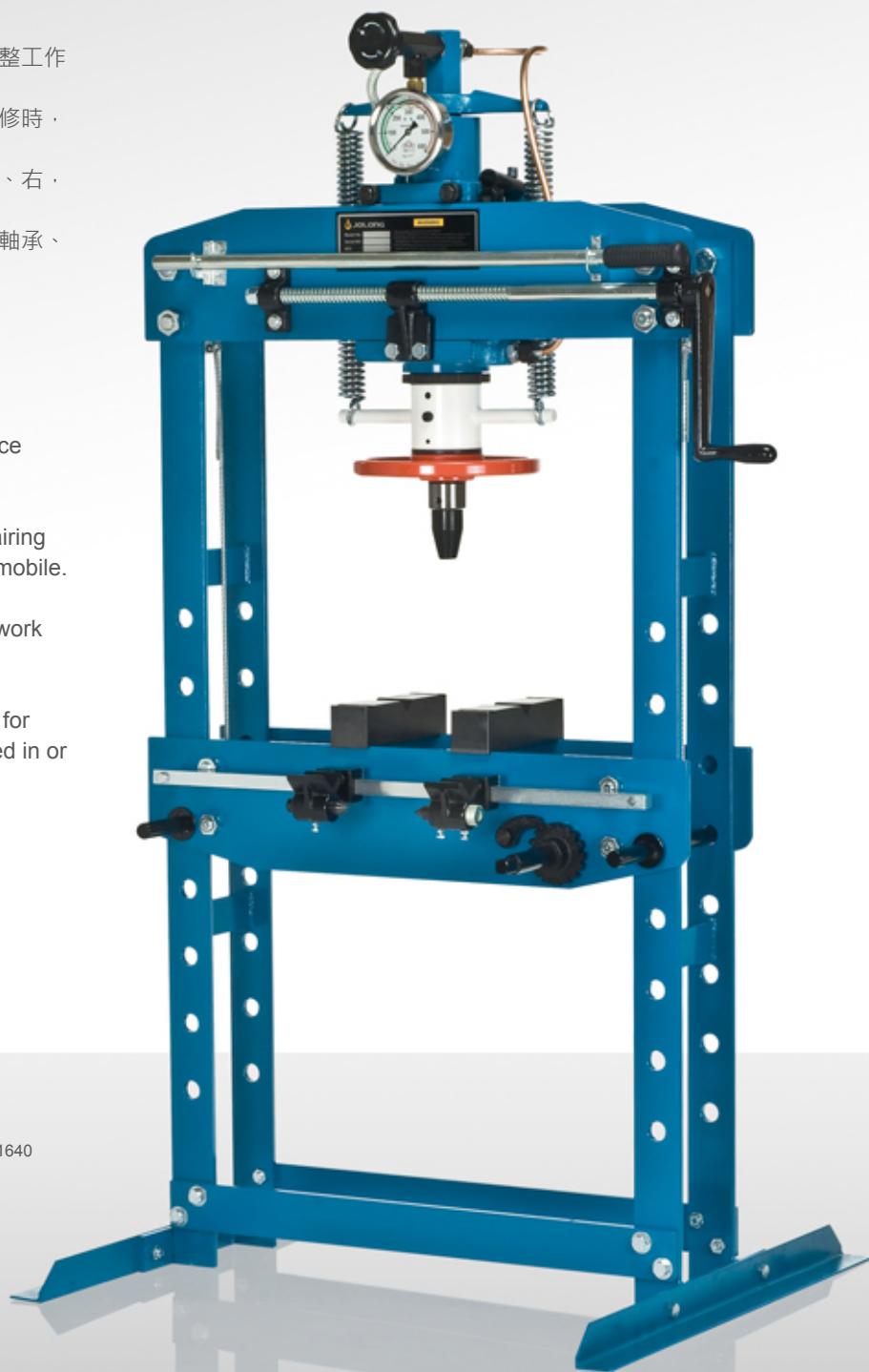
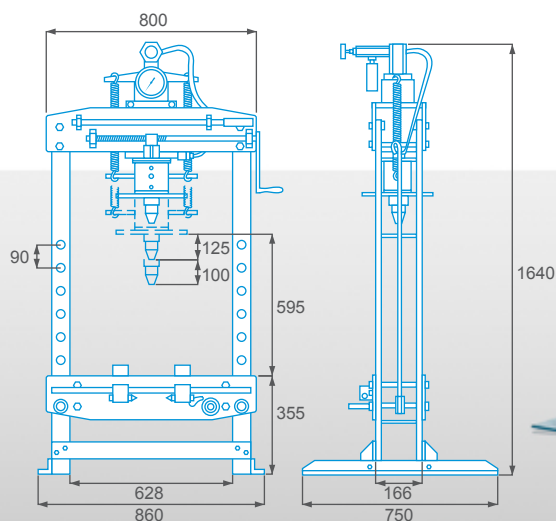

型號 Model	出力 Capacity	油壓缸內徑 Cylinder Bore	輸入壓力 Pressure	油壓缸行程 Cylinder Stroke	包裝方式 Packing	淨重 N.W.	毛重 G.W.	材積 CUFT
HP151	15 TON	ø80 mm	300 kg/cm ²	125 mm	外銷:板條箱 Wooden Crate	172.0 kgs	210.0 kgs	25'

HP351

35 TON 手動油壓床 MANUAL HYDRAULIC PRESS

特點

- (1) 手動操作，無需電力。
- (2) 工作台可依工作物件的大小，上、下自由調整工作距離。
- (3) 專業型手動油壓床，為機械、模具、汽車維修時，不可或缺的利器。
- (4) 油壓主體可依工作物件的大小，上、下、左、右，自由調整工作距離。
- (5) 適用於各種機件彎曲變形、校正、整塑，或軸承、齒輪軸心壓入或逼出等功用。
- (6) 配有雙速高、低壓，操作快速方便，並設有壓力安全閥，當壓力超過40噸以上時，會自動洩壓。

Feature

- (1) Can be operated manually. No electricity is needed.
- (2) Work table can freely adjust working distance (up-down) as per the size of work piece.
- (3) Professional manual hydraulic press: Unnecessary & efficient instrument for repairing and maintaining machinery, mold and automobile.
- (4) Hydraulic main body can adjust freely work distance (up/down/left/right) as per size of work piece.
- (5) Suitable to be applied for such functions as bending, deforming, rectifying, modeling or for bearing and gear shaft arbor getting pressed in or enforcing out.
- (6) Equipped with dual-speed high/low pressure: The operation is quick and convenient. Also, pressure safety valve is also equipped. When pressure exceeds 40 ton and above, it will release pressure automatically.

尺寸圖 Dimension

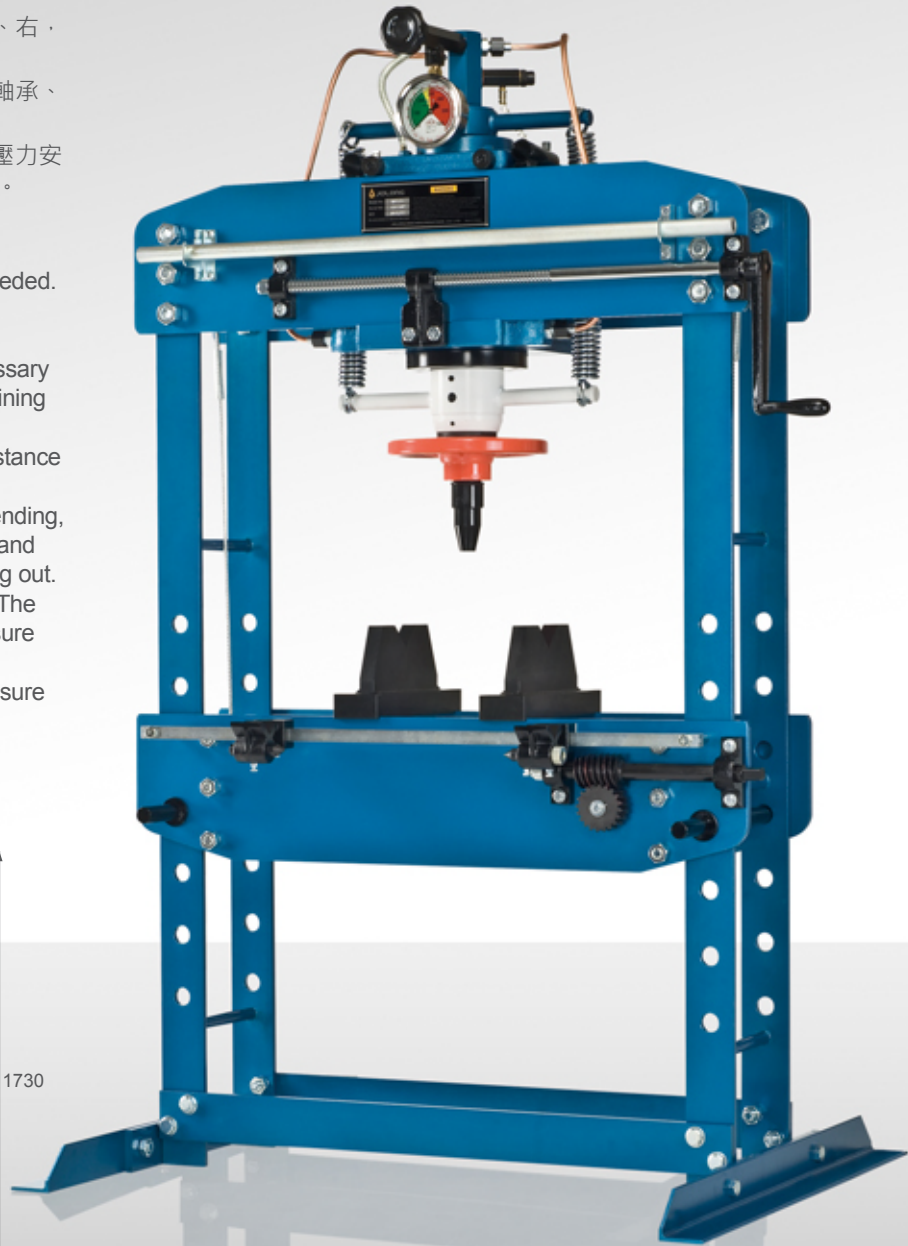
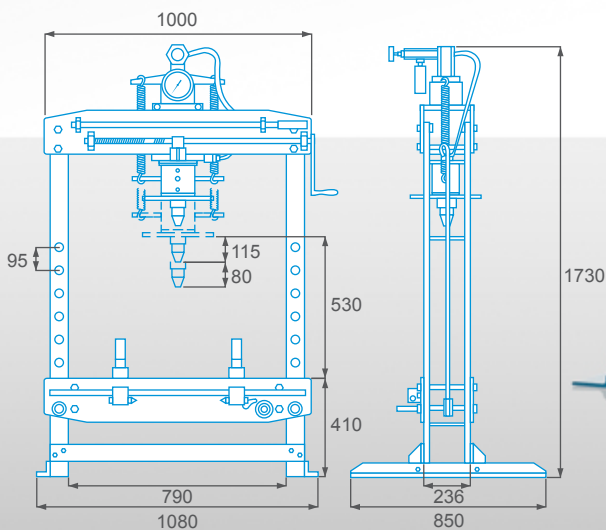

型號 Model	出力 Capacity	油壓缸內徑 Cylinder Bore	輸入壓力 Pressure	油壓缸行程 Cylinder Stroke	包裝方式 Packing	淨重 N.W.	毛重 G.W.	材積 CUFT
HP351	35 TON	φ125 mm	300 kg/cm ²	115 mm	外銷:板條箱 Wooden Crate	310.0 kgs	365.0 kgs	37'